

## Standard type thermal overload relays

### ■ Description

- Highly reliable thermal overload relays
- FUJI thermal overload relays are designed to provide overload protection to meet the thermal characteristics of low voltage induction motors. Adjustable thermal overload relays give motors positive overcurrent protection. The starter contacts cannot be held closing under overload conditions. However, once the bimetal element has cooled, the reset button can be depressed and the motor can be restarted in the normal manner. Ordinarily this reset is carried out manually but the starter can be changed over to 'automatic reset' by means of a screw-driver.
- FUJI thermal overload relay is subjected to stringent testing in the factory to check performance and actual values are calibrated with the markings on the adjustable dial. Consequently, they provide a positive protection.
  - Relays are also provided with ambient temperature compensators, so that their performance will be maintained in spite of temperature changes. The ambient temperature is regulated for 20°C.
  - The heater elements are available for either 2- or 3-pole use.

### Long time operating type

In the case of loads having large inertia moments such as blowers, winders or centrifuges the starting time is extended. This will cause the standard-type thermal overload relay to operate during starting so isolating the motor. If necessary FUJI will supply thermal relays with saturable reactors. (Time-delay type).

### Quick operating type overload relays

The windings of submersible pump and compressor motors normally have a smaller overload capacity than those of standard motors, since they are generally cooled by the water and other medium being pumped. Q type overload relays will operate more quickly than the standard type in the face of a locked rotor current.

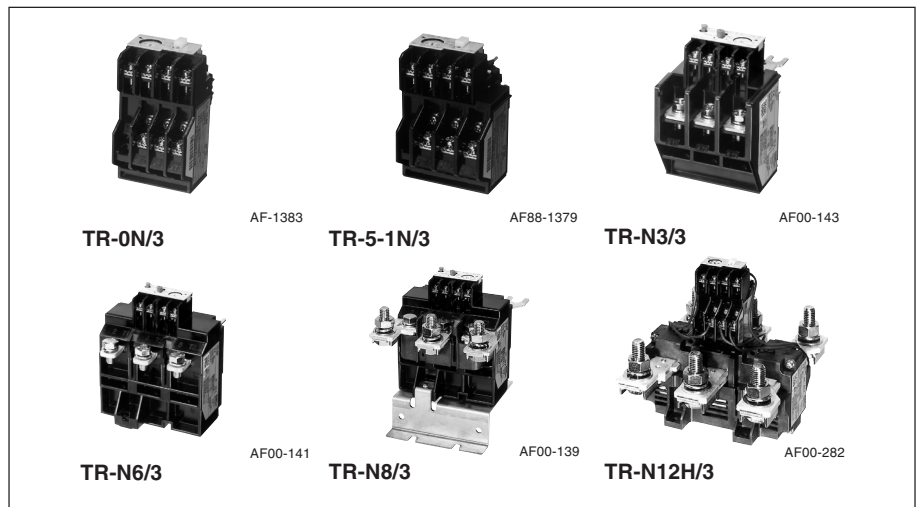

### ■ Features

- Isolated NO and NC contacts can be used with different potentials.
- Gold-flashed silver contact assures high contact reliability (TR-0N/3 to N14/3).
- Stable operating characteristics protect motors from burnout due to overload or locked rotor currents.
- Easy setting of current value with a calibrated dial.
- Both manual and auto reset available. A manual trip button is provided to facilitate sequence testing.
- Mechanical trip indication
- Trip-free mechanism is provided.
- Reset release button and trip indicator are optional accessories.

### ■ Warning

All FUJI thermal overload relays have been tested and calibrated at the factory. They should not be tampered with or stripped down at the job site since this would affect their accuracy. A special feature of the FUJI starter series is the ease by which the relay current ratings can be varied to match the requirements of the load. The changeover is effected by simply turning a dial to the new value required. The range of adjustment is approximately 100%–125%–150% and details are given overleaf.

### ■ Ordering information

Specify the following:  
1. Ordering code  
2. Setting range code  
See page 01/98.

### ■ Type number nomenclature

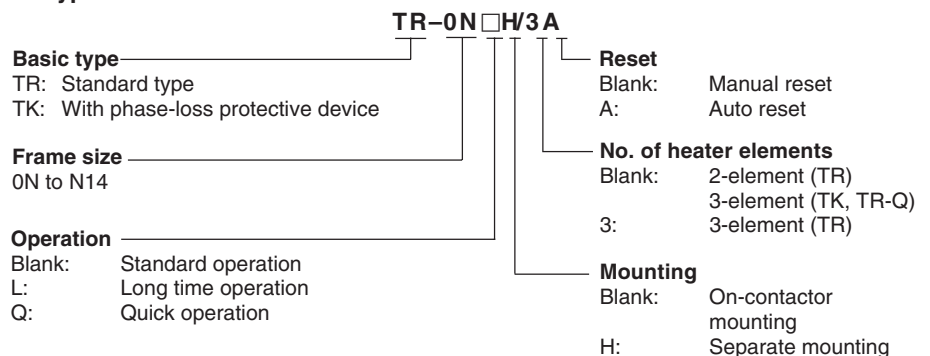

# Thermal Overload Relays

## TR series

### ■ Ordering code system

T R 2 0 B N W — T A  
 ① ② ③④ ⑤ ⑥ ⑦ ⑧ ⑨

#### ① Product category

Description	Code
Thermal overload relay	T

#### ② Series category

Description	Code
TR-N□ series	R

#### ③④ Framesize

Frame size	Code	
	③	④
0N	1	3
5-1N	2	0
N2	3	5
N3	6	5
N5	9	3
N6	1	C
N7	1	F
N8	1	J
N10	2	C
N12	4	A
N14	6	A

#### ⑤ Index

Type	Code
TR-0N, 5-1N	Blank
TR-N2 to N14	B

#### ⑥ Version

Description	No. of element	Code
Standard	2	N
	3	D
Long time operation	2	L
	3	F
Quick operation	3	S
With phase-loss	3	E

#### ⑦ Mounting

Description	Code
On-contactor mounting	W
Separate mounting	H

#### ⑨ Reset

Description	Code
Manual reset	Blank
Auto reaset	A

#### ⑧ Thermal overload relay ampere setting range

Ampere setting range (A)	Code
0.1 — 0.15	A
0.13 — 0.2	B
0.15 — 0.24	C
0.2 — 0.3	D
0.24 — 0.36	E
0.3 — 0.45	F
0.36 — 0.54	G
0.48 — 0.72	H
0.64 — 0.96	J
0.8 — 1.2	K
0.95 — 1.45	L
1.4 — 2.2	M
1.7 — 2.6	N
2.2 — 3.4	P
2.8 — 4.2	R
4 — 6	S
5 — 8	T
6 — 9	U
7 — 11	V
9 — 13	W
12 — 18	X
16 — 22	Q
18 — 26	B
24 — 36	E
28 — 40	F
32 — 42	I
34 — 50	G
45 — 65	J
48 — 68	O
53 — 80	L
65 — 95	M
85 — 105	I
85 — 125	N
110 — 160	P
125 — 185	R
160 — 240	S
200 — 300	T
240 — 360	U
300 — 450	V
400 — 600	W

### Ordering example

① Thermal overload relay ..... T  
 ② TR-□N series ..... R  
 ③④ Frame size: 5-1N ..... 20  
 ⑤ Index ..... Blank  
 ⑥ Standard type, 3-element ..... D  
 ⑦ On-contactor mounting ..... W  
 —  
 ⑧ Ampere setting range 4-6A ..... S  
 ⑨ Auto reset ..... A

TR20DW-SA

① Thermal overload relay ..... T  
 ② TR-N□ series ..... R  
 ③④ Frame size: N3 ..... 65  
 ⑤ Index ..... B  
 ⑥ With phase-loss protection ..... E  
 ⑦ On-contactor mounting ..... W  
 —  
 ⑧ Ampere setting range 24-36A ..... E  
 ⑨ Manual reset ..... Blank

TR65BEW-E

■ Features

● Manual trip

These relays can be manually tripped for sequence inspection by pressing manual trip bar (TR-0N/3, TR-5-1N/3). A sequence inspection will be performed when the test button is pulled out. When the test button is pressed in, only the NC contact will turn OFF. The original status will be restored when the test button is then released.(TR-N2/3 to N8/3)

● Trip-free mechanism

Even if the reset button is carelessly pressed, this relay trips without trouble (Trip-free mechanism).

● Easy visual checking of operating status

Trip indicator and manual trip bar permit visual check of tripping status.

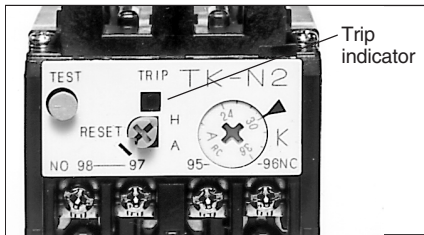

● Dial ampere setting

The setting dial uses a RC (Rated Current) marking which is set to the motor full load current.

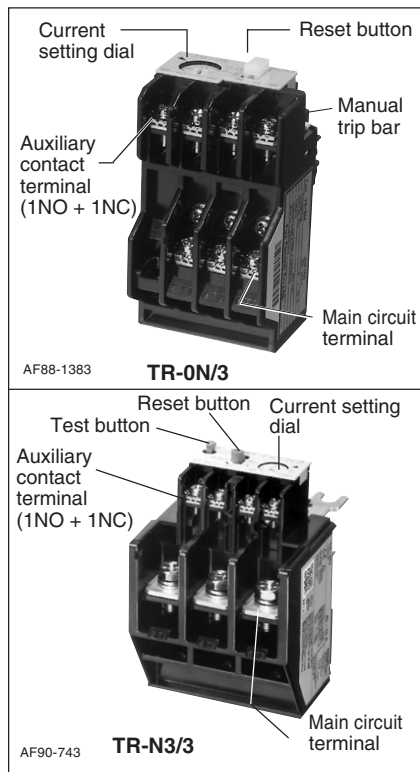

■ Versatile optional accessories  
Trip indicator



Reset release button



Base unit for separate mounting

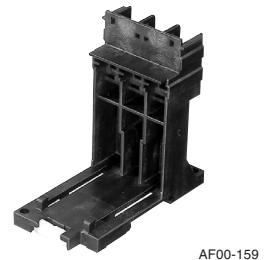

■ Optional accessories

Description	Type	Ordering code	Used with thermal overload relay
Reset release button You can reset these relays remotely on the front panels of switchboards.	Lead length 300 mm	<b>SZ-R1</b>	TZ1R1
	500 mm	<b>SZ-R2</b>	TZ1R2
	700 mm	<b>SZ-R3</b>	TZ1R3
Trip indicator	Lead length 300 mm	<b>SZ-R4</b>	TZ2R4
	500 mm	<b>SZ-R5</b>	TZ2R5
	700 mm	<b>SZ-R6</b>	TZ2R6
Easier checking of trip status	100–110V AC 50/60Hz	<b>SZ-L100</b>	TZ1L100
	200–220V AC 50/60Hz	<b>SZ-L200</b>	TZ1L200
Dial cover For protection against the current setting being changed in error	100–110V AC 50/60Hz	<b>SZ-L100N2</b>	TZ2L100N2
	200–220V AC 50/60Hz	<b>SZ-L200N2</b>	TZ2L200N2
Base unit for separate mounting The unit can be screw-mounted and rail-mounted.	<b>SZ-DA</b>	SZ1DA	TR-0N/3, TR-5-1N/3, TK-0N, TK-5-1N TR-N2/3 to N14/3, TK-N2 to N14
	<b>SZ-HB</b>	TZ1HB	TR-0N/3, TK-0N
	<b>SZ-HC</b>	TZ1HC	TR-5-1N/3, TK-5-1N
	<b>SZ-HD</b>	TZ2HD	TR-N2/3, TK-N2
Terminal cover	<b>SZ-HE</b>	TZ2HE	TR-N3/3, TK-N3
	<b>SZ-T10</b>	SZ1T10	Base unit for separate mounting SZ-HB
	<b>SZ-T11</b>	SZ1T11	Base unit for separate mounting SZ-HC
	<b>SZ-T14</b>	SZ2T14	For separate mounting TR-N2H/3, TK-N2H
	<b>SZ-T15</b>	SZ2T15	For separate mounting TR-N3H/3, TK-N3H
	<b>SZ-RN6T</b>	SZ2RN6T	For separate mounting TR-N6H/3, TK-N6H
	<b>SZ-T12</b>	TZ1T12	TR-0N/3, TK-0N
	<b>SZ-T13</b>	TZ1T13	TR-5-1N/3, TK-5-1N
	<b>SZ-T16</b>	SZ2T16	TR-N2/3, TK-N2
<b>SZ-T17</b>	SZ2T17	TR-N3/3, TK-N2	

# Thermal Overload Relays

## TR series

### Standard type

#### ■ Selection guide/Standard type

On-contactor mounting	3-element 2-element	TR-0N/3 (TR13DW) TR-0N (TR13NW)		TR-5-1N/3 (TR20DW) TR-5-1N (TR20NW)		TR-N2/3 (TR35BDW) TR-N2 (TR35BNW)		TR-N3/3 (TR65BDW) TR-N3 (TR65BNW)	
		TR-0NH/3 (TR13DH) TR-0NH (TR13NH)		TR-5-1NH/3 (TR20DH) TR-5-1NH (TR20NH)		TR-N2H/3 (TR35BDH) TR-N2H (TR35BNH)		TR-N3H/3 (TR65BDH) TR-N3H (TR65BNH)	
Separate mounting		3-element 2-element		3-element 2-element		3-element 2-element		3-element 2-element	
Contactor to be combined		SC-03	SC-0 SC-05	SC-4-0	SC-4-1 SC-5-1	SC-N1	SC-N2	SC-N2S	SC-N3
Ampere setting range (A)	<b>Code</b>	<b>A</b>	0.1 – 0.15	0.1 – 0.15	0.1 – 0.15	0.1 – 0.15			
	<b>B</b>	0.13 – 0.2	0.13 – 0.2	0.13 – 0.2	0.13 – 0.2				
	<b>C</b>	0.15 – 0.24	0.15 – 0.24	0.15 – 0.24	0.15 – 0.24				
	<b>D</b>	0.2 – 0.3	0.2 – 0.3	0.2 – 0.3	0.2 – 0.3				
	<b>E</b>	0.24 – 0.36	0.24 – 0.36	0.24 – 0.36	0.24 – 0.36				
	<b>F</b>	0.3 – 0.45	0.3 – 0.45	0.3 – 0.45	0.3 – 0.45				
	<b>G</b>	0.36 – 0.54	0.36 – 0.54	0.36 – 0.54	0.36 – 0.54				
	<b>H</b>	0.48 – 0.72	0.48 – 0.72	0.48 – 0.72	0.48 – 0.72				
	<b>J</b>	0.64 – 0.96	0.64 – 0.96	0.64 – 0.96	0.64 – 0.96				
	<b>K</b>	0.8 – 1.2	0.8 – 1.2	0.8 – 1.2	0.8 – 1.2				
	<b>L</b>	0.95 – 1.45	0.95 – 1.45	0.95 – 1.45	0.95 – 1.45				
	<b>M</b>	1.4 – 2.2	1.4 – 2.2	1.4 – 2.2	1.4 – 2.2				
	<b>N</b>	1.7 – 2.6	1.7 – 2.6	1.7 – 2.6	1.7 – 2.6				
	<b>P</b>	2.2 – 3.4	2.2 – 3.4	2.2 – 3.4	2.2 – 3.4				
	<b>R</b>	2.8 – 4.2	2.8 – 4.2	2.8 – 4.2	2.8 – 4.2				
	<b>S</b>	4 – 6	4 – 6	4 – 6	4 – 6	4 – 6	4 – 6		
	<b>T</b>	5 – 8	5 – 8	5 – 8	5 – 8	5 – 8	5 – 8		
	<b>U</b>	6 – 9	6 – 9	6 – 9	6 – 9	6 – 9	6 – 9		
	<b>V</b>	7 – 11	7 – 11	7 – 11	7 – 11	7 – 11	7 – 11	7 – 11	7 – 11
	<b>W</b>		9 – 13	9 – 13	9 – 13	9 – 13	9 – 13	9 – 13	9 – 13
<b>X</b>			12 – 18	12 – 18	12 – 18	12 – 18	12 – 18	12 – 18	
<b>Q</b>				16 – 22					
<b>B</b>					18 – 26	18 – 26	18 – 26	18 – 26	
<b>E</b>					24 – 36	24 – 36	24 – 36	24 – 36	
<b>F</b>							28 – 40	28 – 40	
<b>I</b>							32 – 42		
<b>G</b>								34 – 50	
<b>J</b>								45 – 65	
<b>O</b>								48 – 68	
<b>L</b>								53 – 80*	
<b>M</b>								65 – 95*	
<b>I</b>								85 – 105*	

On-contactor mounting	3-element 2-element	TR-N5/3 (TR80BDW) TR-N5 (TR80BNW)		TR-N6/3 (TR1CBDW) TR-N6 (TR1CBNW)		TR-N7/3 (TR1FBDW) TR-N7 (TR1FBNW)		TR-N8/3 (TR1JBDW) TR-N8 (TR1JBNW)		TR-N10/3 (TR2CBDW) TR-N10 (TR2CBNW)		TR-N12/3 (TR4ABDW) TR-N12 (TR4ABNW)		TR-N14/3 (TR8ABDW) TR-N14 (TR8ABNW)	
		TR-N6H/3 (TR1CBDH) TR-N6H (TR1CBNH)		TR-N10H/3 (TR2CBDH) TR-N10H (TR2CBNH)		TR-N12H/3 (TR4ABDH) TR-N12H (TR4ABNH)		TR-N14H/3 (TR8ABDH) TR-N14H (TR8ABNH)							
Separate mounting		3-element 2-element		3-element 2-element		3-element 2-element		3-element 2-element		3-element 2-element		3-element 2-element			
Contactor to be combined		SC-N4	SC-N5	SC-N6	SC-N7	SC-N8	SC-N10	SC-N11	SC-N12	SC-N14					
Ampere setting range (A)	<b>Code</b>	<b>B</b>	18 – 26	18 – 26											
	<b>E</b>	24 – 36	24 – 36												
	<b>F</b>	28 – 40	28 – 40												
	<b>G</b>	34 – 50	34 – 50												
	<b>J</b>	45 – 65	45 – 65	45 – 65	45 – 65										
	<b>L</b>	53 – 80	53 – 80	53 – 80	53 – 80										
	<b>M</b>		65 – 95	65 – 95	65 – 95	65 – 95									
	<b>I</b>		85 – 105												
	<b>N</b>			85 – 125	85 – 125	85 – 125	85 – 125								
	<b>P</b>			110 – 160*	110 – 160	110 – 160	110 – 160	110 – 160	110 – 160	110 – 160					
	<b>R</b>					125 – 185	125 – 185	125 – 185	125 – 185	125 – 185					
	<b>S</b>						160 – 240	160 – 240	160 – 240	160 – 240					
	<b>T</b>							200 – 300	200 – 300	200 – 300					
	<b>U</b>								240 – 360	240 – 360					
<b>V</b>								300 – 450	300 – 450						
<b>W</b>									400 – 600						

- Notes:
- TR-N10/3 to N14/3 types are provided with CTs.
  - Max. setting ranges of these starters are as shown in the table on the right.
  - When ordering the thermal overload relays for starter use, select the applicable setting range.
- ( ) : Basic ordering code (When ordering phase-loss protective type, enter the version code E instead of D)
- \* : Separate mounting only

Motor starter	Maximum applicable heater range (A)	
	200–240V	380–440V
SW-03/3H	7–11	6–9
SW-4-0/3H	12–18	12–18
SW-N1/3H	24–36	24–36
SW-N2S/3H	34–50	34–50
SW-N4/3H	53–80	53–80
SW-N6/3H	85–125	85–125

■ Selection guide/Long time operating type

On-contactor mounting	3-element	-		-		TR-N2L/3 (TR35BFW)		TR-N3L/3 (TR65BFW)	
	2-element	-		-		TR-N2L (TR35BLW)		TR-N3L (TR65BLW)	
Separate mounting	3-element	TR-0NLH/3 (TR13FH)		TR-5-1NLH/3 (TR20FH)		TR-N2LH/3 (TR35BFH)		TR-N3LH/3 (TR65BFH)	
	2-element	TR-0NLH (TR13LH)		TR-5-1NLH (TR20LH)		TR-N2LH (TR35BLH)		TR-N3LH (TR65BLH)	
Contactor to be combined		SC-03	SC-0 SC-05	SC-4-0	SC-4-1 SC-5-1	SC-N1	SC-N2	SC-N2S	SC-N3
Ampere setting range (A)	<b>Code</b>	L	0.95 – 1.45	0.95 – 1.45	0.95 – 1.45	0.95 – 1.45			
	M	1.4 – 2.2	1.4 – 2.2	1.4 – 2.2	1.4 – 2.2				
	N	1.7 – 2.6	1.7 – 2.6	1.7 – 2.6	1.7 – 2.6				
	P	2.2 – 3.4	2.2 – 3.4	2.2 – 3.4	2.2 – 3.4				
	R	2.8 – 4.2	2.8 – 4.2	2.8 – 4.2	2.8 – 4.2				
	S	4 – 6	4 – 6	4 – 6	4 – 6	4 – 6	4 – 6		
	T	5 – 8	5 – 8	5 – 8	5 – 8	5 – 8	5 – 8		
	U	6 – 9	6 – 9	6 – 9	6 – 9	6 – 9	6 – 9		
	V	7 – 11	7 – 11	7 – 11	7 – 11	7 – 11	7 – 11	7 – 11	7 – 11
	W		9 – 13	9 – 13	9 – 13	9 – 13	9 – 13	9 – 13	9 – 13
	X			12 – 18	12 – 18	12 – 18	12 – 18	12 – 18	12 – 18
	B					18 – 26	18 – 26	18 – 26	18 – 26
	E						24 – 36	24 – 36	24 – 36
F							28 – 40	28 – 40	
G							34 – 50	34 – 50	
J								45 – 65	
L								53 – 80*	
M								65 – 95*	

On-contactor mounting	3-element	TR-N5L/3 (TR80BFW)		TR-N6L/3 (TR1CBFW)	TR-N7L/3 (TR1FBFW)	TR-N10L/3 (TR2CBFW)		TR-N12L/3 (TR4ABFW)		TR-N14L/3 (TR8ABFW)	
	2-element	TR-N5L (TR80BLW)		TR-N6L (TR1CBLW)	TR-N7L (TR1FBLW)	TR-N10L (TR2CBLW)		TR-N12L (TR4ABLW)		TR-N14L (TR8ABLW)	
Separate mounting	3-element	-		TR-N6LH/3 (TR1CBFH)	-	TR-N10LH/3 (TR2CBFH)		TR-N12LH/3 (TR4ABFH)		TR-N14LH/3 (TR8ABFH)	
	2-element	-		TR-N6LH (TR1CBLH)	-	TR-N10LH (TR2CBLH)		TR-N12LH (TR4ABLH)		TR-N14LH (TR8ABLH)	
Contactor to be combined		SC-N4	SC-N5	SC-N6	SC-N7	SC-N8	SC-N10	SC-N11	SC-N12	SC-N14	
Ampere setting range (A)	<b>Code</b>	B	18 – 26	18 – 26							
	E	24 – 36	24 – 36								
	F	28 – 40	28 – 40								
	G	34 – 50	34 – 50								
	J	45 – 65	45 – 65	45 – 65	45 – 65						
	L	53 – 80	53 – 80	53 – 80	53 – 80						
	M		65 – 95	65 – 95	65 – 95						
	N			85 – 125	85 – 125	85 – 125	85 – 125				
	P			110 – 160*	110 – 160	110 – 160	110 – 160	110 – 160	110 – 160	110 – 160	
	R					125 – 185	125 – 185	125 – 185	125 – 185	125 – 185	
	S						160 – 240	160 – 240	160 – 240	160 – 240	
	T							200 – 300	200 – 300	200 – 300	
	U								240 – 360	240 – 360	240 – 360
V								300 – 450	300 – 450	300 – 450	
W									400 – 600	400 – 600	

Notes: Maximum setting ranges of the these starters are as shown in the table below. ( ): Basic ordering code  
Select the applicable setting range when ordering the thermal overload relays for starter use. \*: Separate mounting only

Motor starter	Maximum applicable heater range (A)	
	200–240V	380–440V
SW-03/2L, 3L	7–11	6–9
SW-N2S/2L, 3L	34–50	34–50
SW-N4/2L, 3L	53–80	53–80
SW-N6/2L, 3L	85–125	85–125

# Thermal Overload Relays

## TR series

### Quick operating type

#### ■ Selection guide/Quick operating type

On-contactor mounting	3-element	<b>TR-0NQ</b> (TR13SW)		<b>TR-5-1NQ</b> (TR20SW)		<b>TR-N2Q</b> (TR35BSW)	
Separate mounting	3-element	-		-		-	
Contactor to be combined		SC-03	SC-0 SC-05	SC-4-0	SC-4-1 SC-5-1	SC-N1	SC-N2
Rated operational current (A)	200-240V 380-440V	11 9	13 12	18 16	22 22	27 30	39 37
Ampere setting range (A)	<b>Code</b>	<b>M</b>	1.4 - 2.2	1.4 - 2.2	1.4 - 2.2	1.4 - 2.2	
		<b>N</b>	1.7 - 2.6	1.7 - 2.6	1.7 - 2.6	1.7 - 2.6	
		<b>P</b>	2.2 - 3.4	2.2 - 3.4	2.2 - 3.4	2.2 - 3.4	
		<b>R</b>	2.8 - 4.2	2.8 - 4.2	2.8 - 4.2	2.8 - 4.2	
		<b>S</b>	4 - 6	4 - 6	4 - 6	4 - 6	
		<b>T</b>	5 - 8	5 - 8	5 - 8	5 - 8	
		<b>U</b>	6 - 9	6 - 9	6 - 9	6 - 9	
		<b>V</b>	7 - 11 *1	7 - 11 *1	7 - 11 *1	7 - 11 *1	
		<b>W</b>		9 - 13 *1	9 - 13 *1	9 - 13 *1	
		<b>X</b>			12 - 18 *1	12 - 18 *1	12 - 18
		<b>B</b>				18 - 26	18 - 26
		<b>E</b>					24 - 36

On-contactor mounting	3-element	<b>TR-N3Q</b> (TR65BSW)		<b>TR-N5Q</b> (TR80SW)	
Separate mounting	3-element	<b>TR-N3Q</b> (TR65BSW)		-	
Contactor to be combined		SC-N2S	SC-N3	SC-N4	SC-N5
Rated operational current (A)	200-240V 380-440V	52 48	65 65	80 80	105 105
Ampere setting range (A)	<b>Code</b>	<b>B</b>	18-26	18-26	18-26
		<b>E</b>	24-36	24-36	24-36
		<b>F</b>	28-40	28-40	28-40
		<b>G</b>	34-50	34-50	34-50
		<b>J</b>		45-65	45-65
		<b>L</b>		53-80*2	53-80
		<b>M</b>		65-95*2	65-95

Notes: \*1 Thermal overload relay with phase-loss protection is available with \*1 marked setting ranges of TR-0NQ, TR-5-1NQ and all setting ranges of TR-N2Q to N5Q.

Type numbers are TK-0NQ, TK-5-1NQ, TK-N2Q to N5Q. The setting ranges of these TK-□Q type relays are as same as those of the above setting ranges.

\*2 Separate mounting only.

( ) Basic ordering code

#### ■ Ratings of auxiliary contact

Type	Rated thermal current (A)	Rated voltage (V)	Rated AC operational current (A)	Rated DC operational current (A)
TR-0N, 5-1N TR-0N/3, 5-1N/3 TK-0N, 5-1N TR-0NQ, 5-1NQ	3	24 100-120 200-240 380-440 500-600	3 (0.3)* 2.5 (0.3)* 2 (0.3)* 1 (0.3)* 0.6 (0.3)*	1.1 (0.3)* 0.28 0.14 - -
TR-N2 to N8 TR-N2/3 to N8/3 TK-N2 to N8 TR-N2Q to N5Q	5	24 100-120 200-240 380-440 500-600	3 (0.5)* 2.5 (0.5)* 2 (0.5)* 1 (0.5)* 0.6 (0.5)*	1.1(0.3)* 0.28 0.14 - -
TR-N10 to N14 TR-N10/3 to N14/3 TK-N10 to N14	5	24 100-120 200-240 380-440 500-600	3 (0.3)* 2.5 (0.3)* 2 (0.3)* 1 (0.3)* 0.6 (0.3)*	1.1(0.3)* 0.28 0.14 - -

Notes: Conforming to Class AC-15, DC-13, IEC, JIS, and JEM.

( ) \* NO contact of auto reset type.

■ Dimensions, mm  
Standard and quick operating types  
TR-0N/3, TR-0NQ  
On-contactor mounting

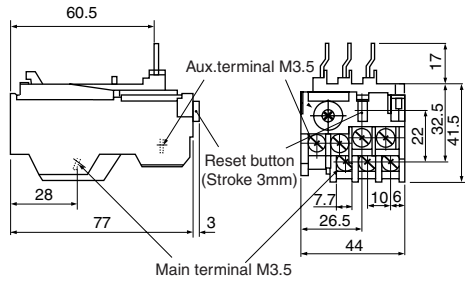

TR-0NH/3

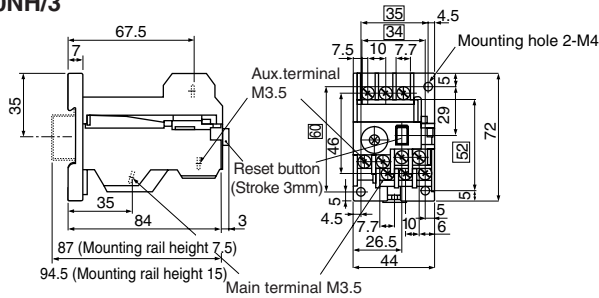

TR-5-1N/3, TR-5-1NQ  
On-contactor mounting

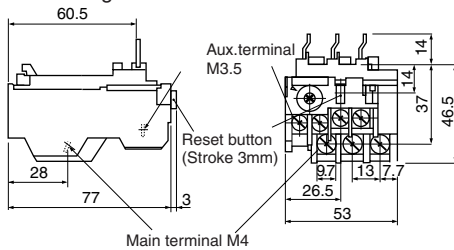

TR-5-1NH/3

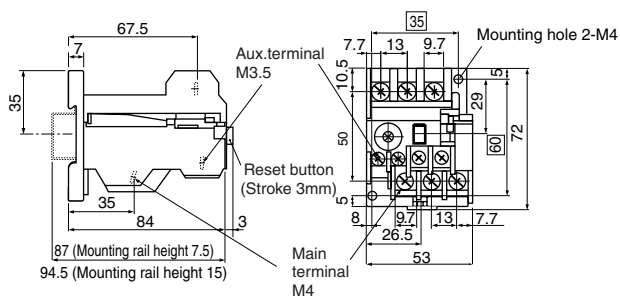

TR-N2/3, TR-N2Q  
On-contactor mounting

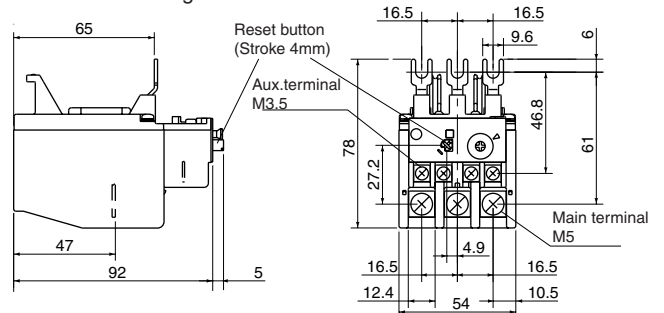

TR-N2H/3

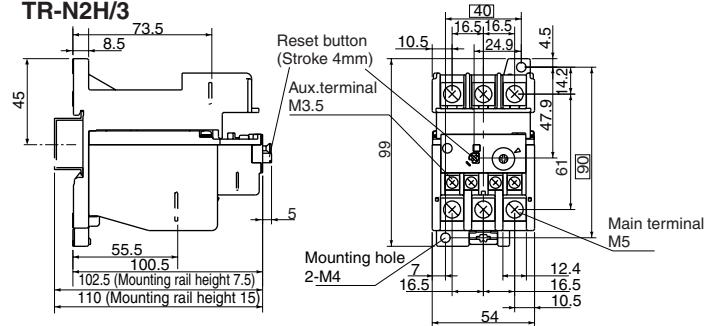

TR-N3/3, TR-N3Q  
On-contactor mounting

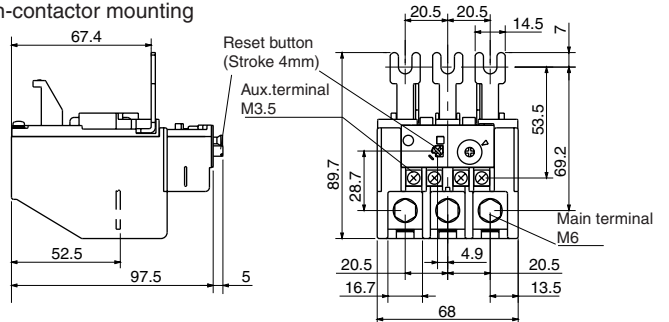

TR-N3H/3

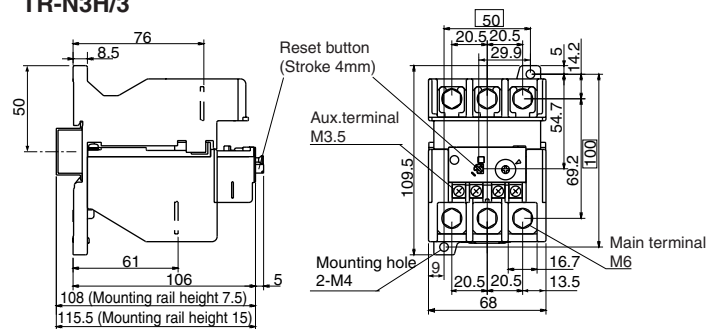

TR-N5/3, TR-N5Q  
On-contactor mounting

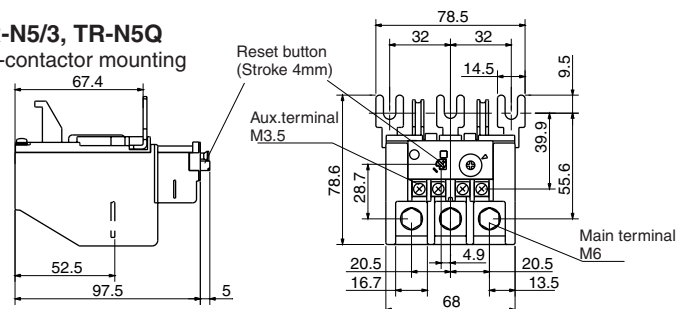

□ : Mounting pitch  
Mass: See page 01/105.

# Thermal Overload Relays TR series

## ■ Dimensions, mm Standard and quick operating types

### TR-6N/3

On-contactor mounting

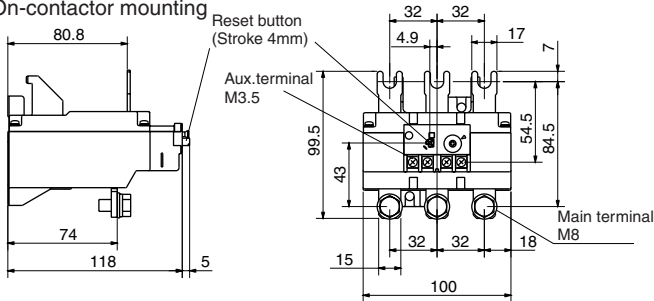

### TR-N6H/3

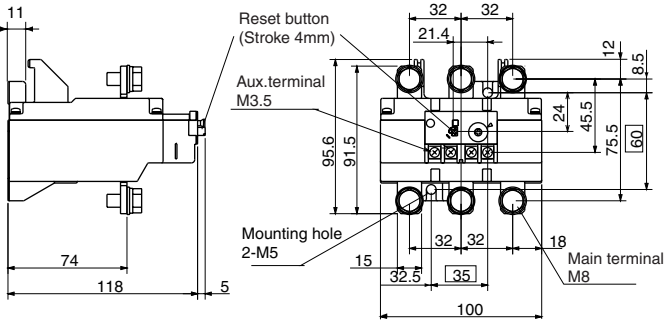

### TR-N7/3

On-contactor mounting

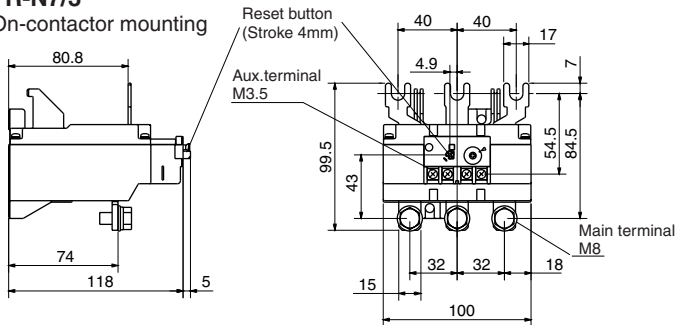

### TR-N8/3

On-contactor mounting

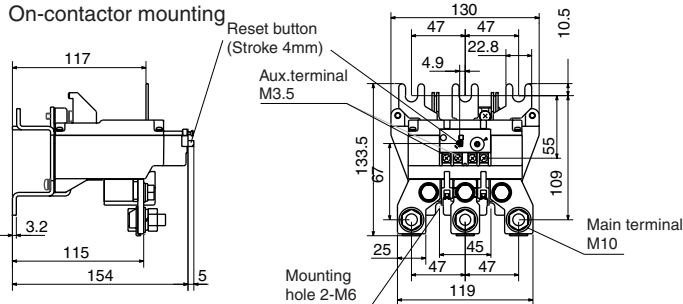

### TR-N10/3

On-contactor mounting

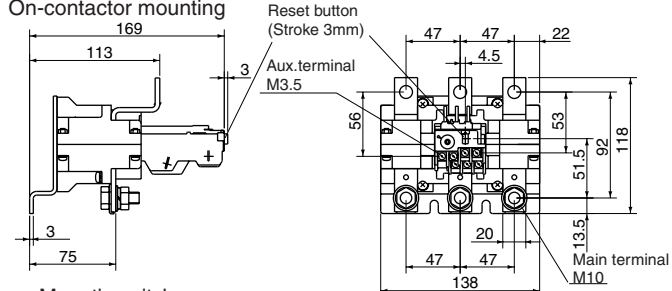

### TR-N10H/3

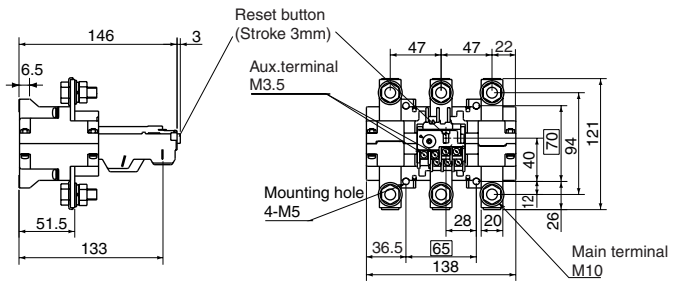

### TR-N12/3

On-contactor mounting

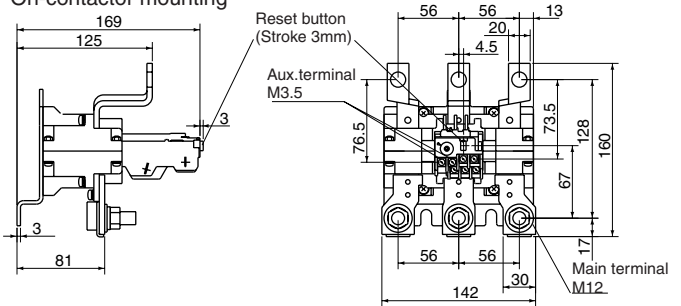

### TR-N12H/3

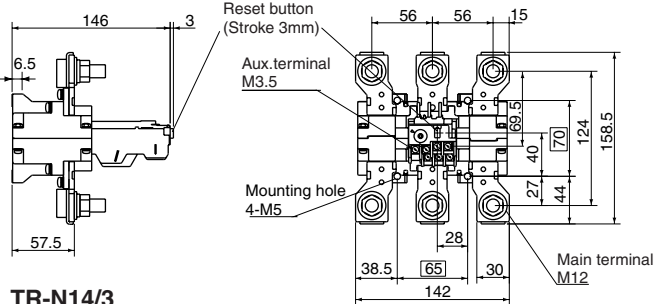

### TR-N14/3

On-contactor mounting

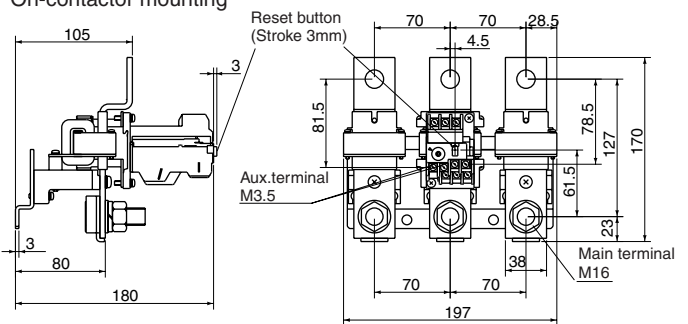

### TR-N14H/3

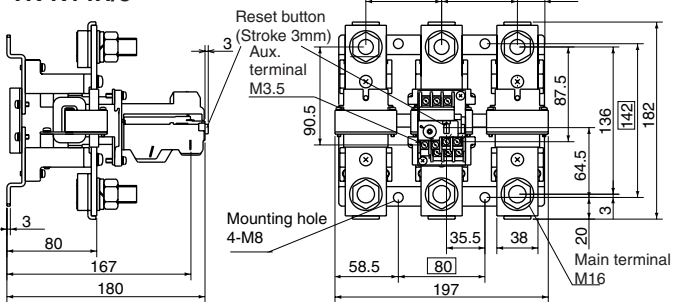

□ : Mounting pitch  
Mass: See page 01/105.

■ Dimensions, mm

Base unit for separate mounting

SZ-HB

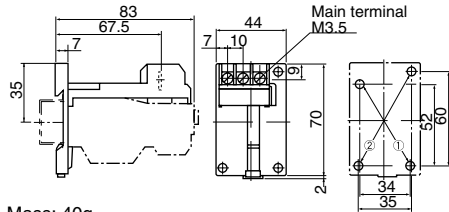

Mass: 40g

SZ-HC

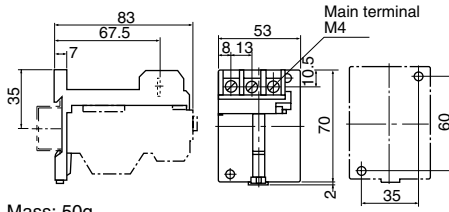

Mass: 50g

SZ-HD

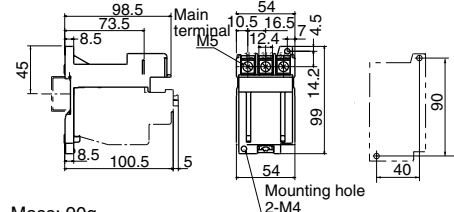

Mass: 90g

SZ-HE

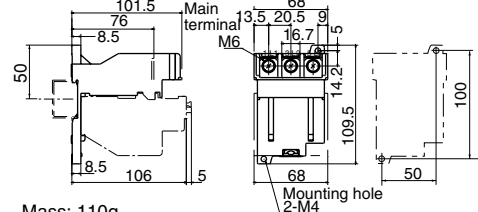

Mass: 110g

■ Mass/Standard and quick operating types

On-contactor mounting		Separate mounting		On-contactor mounting		Separate mounting	
Type	Mass	Type	Mass	Type	Mass	Type	Mass
TR-0N	0.09kg	TR-0NH	0.13kg	TR-N7	0.61kg		
TR-0N/3	0.10kg	TR-0NH/3	0.14kg	TR-N7/3	0.61kg		
TR-0NQ	0.10kg						
TR-5-1N	0.11kg	TR-5-1NH	0.16kg	TR-N8	1.2kg		
TR-5-1N/3	0.12kg	TR-5-1NH/3	0.17kg	TR-N8/3	1.2kg		
TR-5-1NQ	0.12kg						
TR-N2, N2/3	0.2kg	TR-N2H	0.29kg	TR-N10	1.85kg	TR-10NH	1.5kg
TR-N2Q	0.2kg	TR-N2H/3	0.29kg	TR-N10/3	1.85kg	TR-10NH/3	1.5kg
TR-N3, N3/3	0.27kg	TR-N3H, N3H/3	0.38kg	TR-N12, N12/3	2.3kg	TR-12NH, 12NH/3	2.25kg
TR-N3Q	0.27kg						
TR-N5, N5/3	0.27kg			TR-N14, N14/3	3.5kg	TR-14NH, 14NH/3	4kg
TR-N5Q	0.27kg						
TR-N6, N6/3	0.61kg	TR-N6H, N6H/3	0.67kg				

■ Dimensions, mm

Long time operating type

TR-0NLH, 0NLH/3

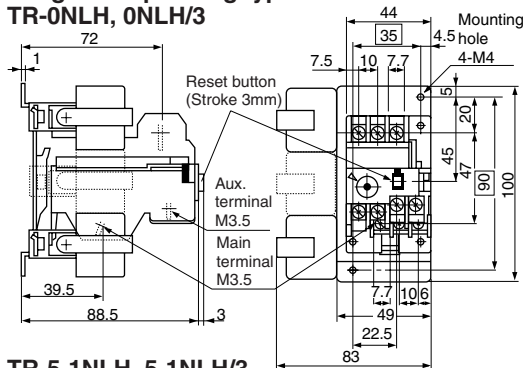

TR-5-1NLH, 5-1NLH/3

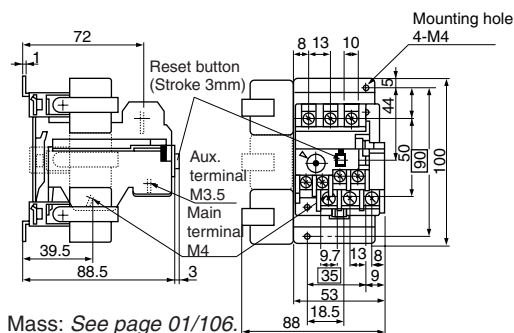

Mass: See page 01/106.

TR-N2L, N2L/3

On-contactor mounting

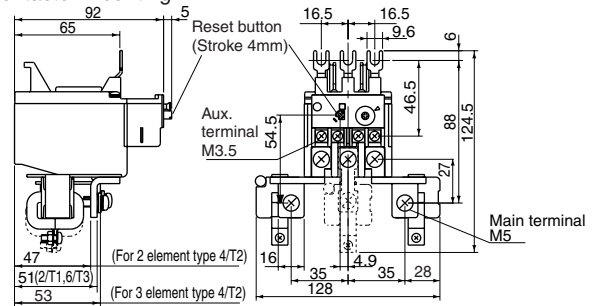

TR-N2LH, N2LH/3

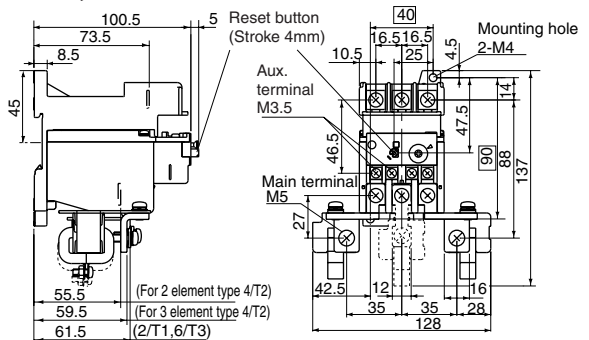



■ Dimensions, mm  
Optional accessories  
Trip indicator

SZ-L100  
SZ-L200

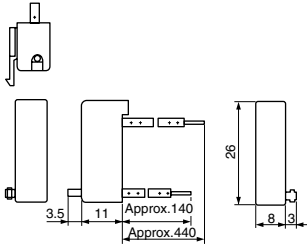

SZ-L100N2  
SZ-L200N2

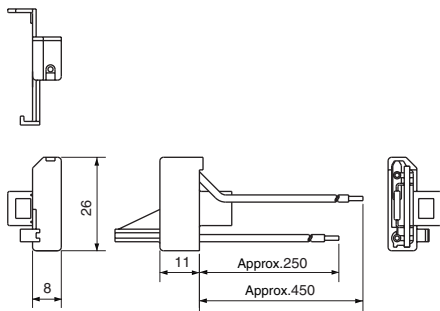

Reset release button

SZ-R1  
SZ-R2  
SZ-R3

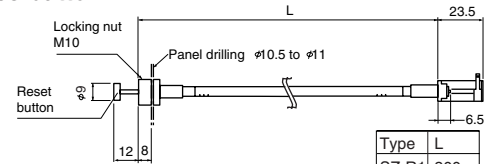

Type	L
SZ-R1	300
SZ-R1	500
SZ-R1	700

SZ-R4  
SZ-R5  
SZ-R6

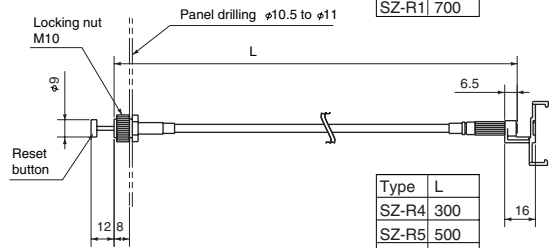

Type	L
SZ-R4	300
SZ-R5	500
SZ-R6	700

Dial cover  
SZ-DA

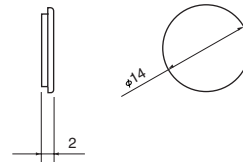

■ Characteristic curves These curves show cold starting characteristics.

● Standard type

TR-0N, 5-1N,  
TR-0N/3, 5-1N/3,  
TR-0NH, 5-1NH,  
TR-0NH/3, 5-1NH/3

TR-N2 to N8  
TR-N2/3 to N8/3  
TR-N2H, N3H, N6H  
TR-N2H/3, N3H/3, N6H/3

TR-N10 to N14,  
TR-N10/3 to N14/3,  
TR-N10H to N14H  
TR-N10H/3 to N14H/3

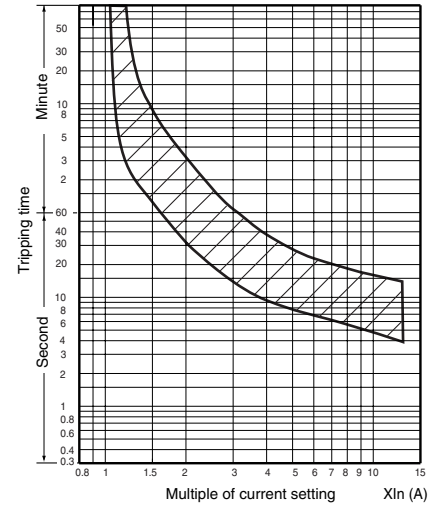
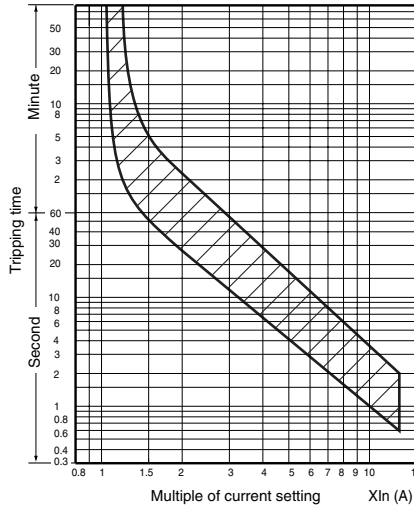
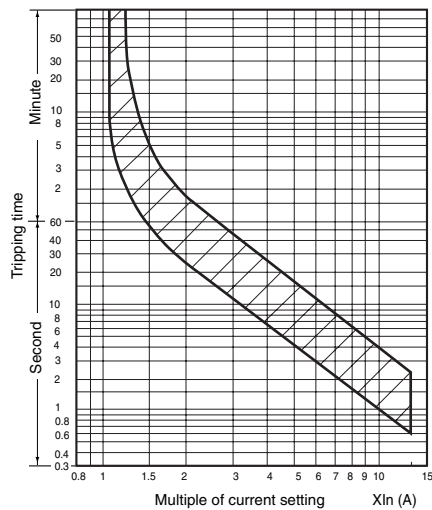

■ Wiring diagrams

● Standard type

TR-0N to N8  
TR-0N/3 to N8/3  
TR-0NH, 5-1NH, N2H, N3H, N6H  
TR-0NH/3, 5-1NH/3, N2H/3, N3H/3, N6H/3

2-element

3-element

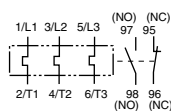
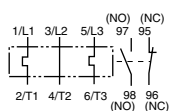

TR-N10 to N14  
TR-N10/3 to N14/3  
TR-N10H to N14H  
TR-N10H/3 to N14H/3

2-element  
(with CTs)

3-element  
(with CTs)

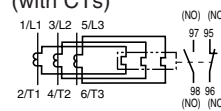
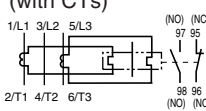

# Thermal Overload Relays TR series

■ **Characteristic curves** These curves show cold starting characteristics

● **Long time operating type** (When setting at the center dial current)

TR-0NL, 5-1NL

TR-0NL/3, 5-1NL/3

TR-0NLH, 5-1NLH

TR-0NLH/3, 5-1NLH/3

TR-N2L to N7L

TR-N2L/3 to N7L/3

TR-N2LH, N3LH, N6LH

TR-N2LH/3, N3LH/3, N6LH/3

TR-N10L to N14L

TR-N10L/3 to N14L/3

TR-N10LH to N14LH

TR-N10LH/3 to N14LH/3

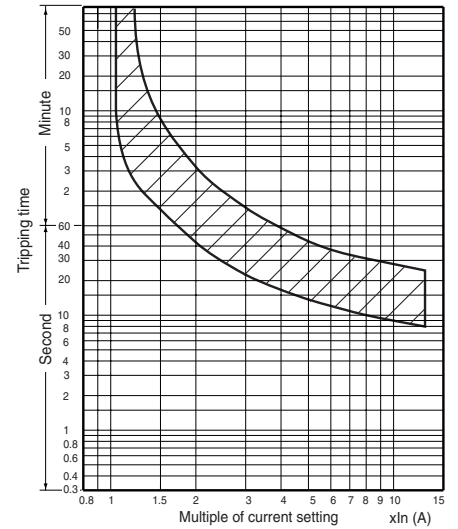
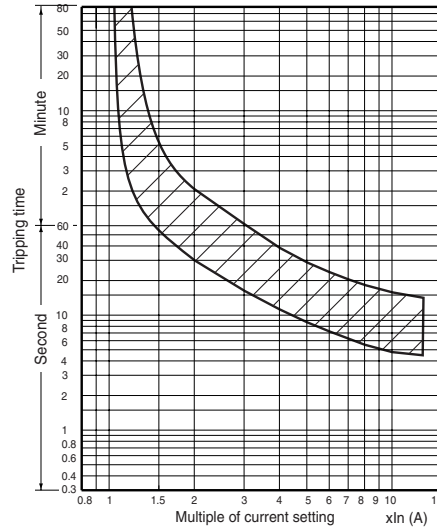
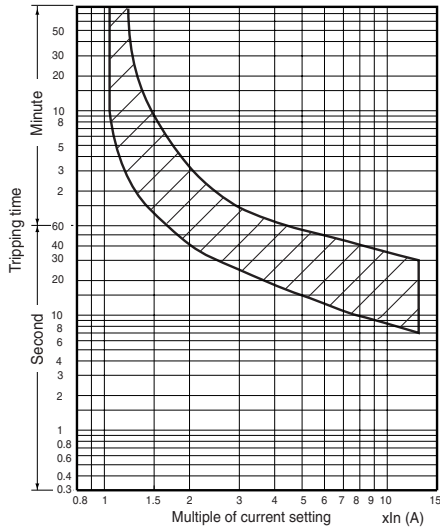

● **Quick operating type**

TR-0NQ, 5-1NQ

TR-N2Q, N3Q, N5Q

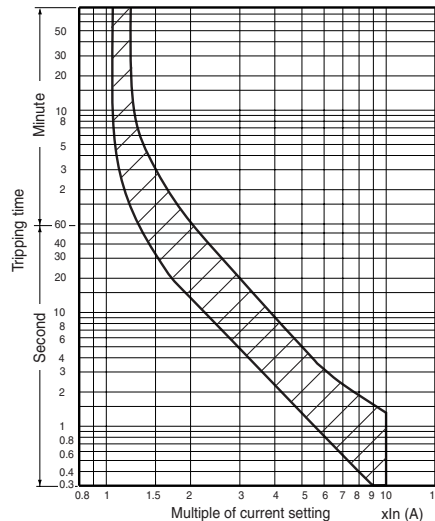
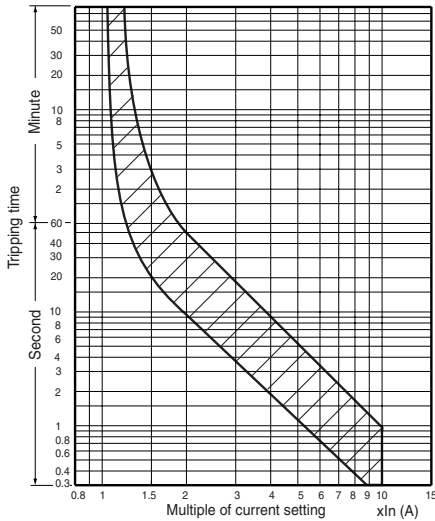

■ **Wiring diagrams**

● **Long time operating type**

TR-0NL to N7L

TR-0NL/3 to N7L/3

TR-0NLH, 5-1NLH, N2LH, N3LH, N6LH

TR-0NLH/3, 5-1NLH/3, N2LH/3, N3LH/3, N6LH/3

● **Quick operating type**

TR-0NQ, 5-1NQ

TR-N2Q, N3Q, N5Q

2-element

3-element

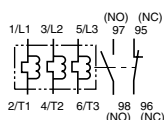
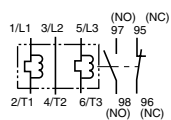

2-element  
(with CTs)

3-element  
(with CTs)

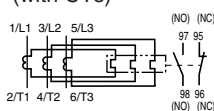
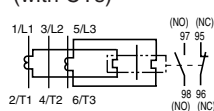

3-element

