

Bifurcated contacts with excellent electrical conductivity/SH-4, SH-5

■ **Description**

SH series industrial relays are designed to increase contact reliability and make them easy to use. The relays' highly reliable, bifurcated contacts allow them to be used in low-level circuits of 5V, 3mA. Various optional function units such as auxiliary contact blocks, coil surge suppression units can be added to the relays, allowing fast and field modification.

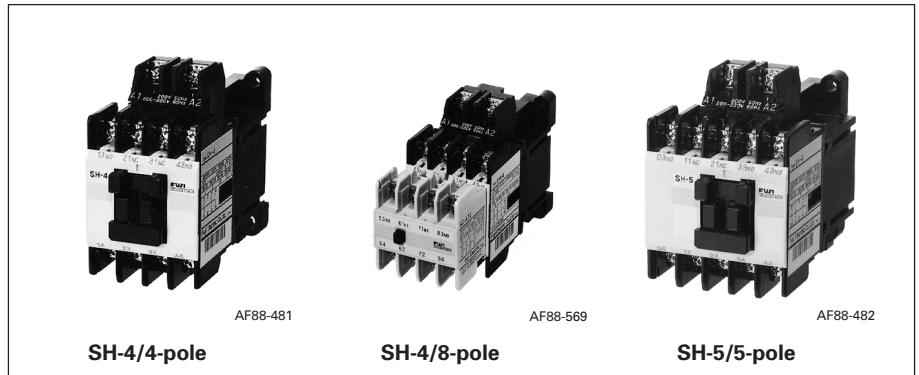

03

■ **Types and ratings**

Type	SH-4			SH-5		
Pole	4			8		
Contact arrangement	4NO, 3NO+1NC, 2NO+2NC			8NO, 7NO+1NC, 6NO+2NC 5NO+3NC, 4NO+4NC		
Thermal current (A)	10			10		
Rated operational current (A)	Volts	AC-15 (ind.)	AC-12 (res.)	Volts	DC-13 (ind.)	DC-12 (res.)
	110V AC	6	10	24V DC	3	5
	220V AC	3	8	48V DC	1.5	3
	440V AC	1.5	5	110V DC	0.55	2.5
	550V AC	1.2	5	220V DC	0.27	1
Standard operating coil voltage	100V 50Hz/100–110V 60Hz, 200V 50Hz/200–220V 60Hz, 380V–400V 50Hz/400–440V 60Hz					
Mechanical durability	10 million operations					
Electrical durability (AC-15)	500,000 operations (at operational current)					
Operating cycles per hour	1,800					
Ambient temperature	–5 to +50°C					

■ **Ordering code system**

S H 04 A A-1 22

① ② ③④ ⑤ ⑥ ⑦ ⑧⑨

① **Product category**

Description	Code
Industrial relay	S

② **Series category**

Description	Code
SH series	H

③④ **Frame size**

Frame size	Code	
	③	④
SH-4	0	4
SH-5	0	5

⑤ **Version**

Description	Code
Standard	A

⑥ **Coil/contact specification**

Description	Code
Standard	
AC operated	A
DC operated	G
With extra pick-up coil	U
Mechanical latch	
AC operated	V
DC operated	D
With single-button contact	H

⑦ **Coil voltage**

Coil voltage	Code
24V 50Hz/24–26V 60Hz	E
48V 50Hz/48–52V 60Hz	F
100V 50Hz/100–110V 60Hz	1
100–110V 50Hz/110–120V 60Hz	H
110–120V 50Hz/120–130V 60Hz	K
200V 50Hz/200–220V 60Hz	2
200–220V 50Hz/220–240V 60Hz	M
220–240V 50Hz/240–260V 60Hz	P
346–380V 50Hz/380–420V 60Hz	S
380–400V 50Hz/400–440V 60Hz	4
415–440V 50Hz/440–480V 60Hz	T
480–500V 50Hz/500–550V 60Hz	5
24V DC	E
48V DC	F
100V DC	1
110V DC	H
200V DC	2
220V DC	M

⑧⑨ **Contact arrangement**

Contact arrangement	Code	
	⑧	⑨
4NO	4	0
3NO+1NC	3	1
2NO+2NC	2	2
8NO	8	0
7NO+1NC	7	1
6NO+2NC	6	2
5NO+3NC	5	3
4NO+4NC	4	4
5NO	5	0
4NO+1NC	4	1
3NO+2NC	3	2
2NO+3NC	2	3
1NO+4NC	1	4
5NC	0	5

Industrial Relays

SH series

General information

Optional units

Front mounting

Auxiliary contact block

2 or 4-pole

Highly reliable bifurcated contact can be used in low-level circuit of 5V, 3mA.

Operation counter

This counter indicates the number of relay ON-OFF operations to ensure easy maintenance and inspection.

Terminal cover

The relay can easily be fitted with terminal covers for finger safety.

Top mounting

Coil drive unit

This unit controls ON-OFF operation for industrial relay with output from electronic equipment.

Coil surge suppression unit

This unit absorbs coil surge voltage due to relay ON-OFF operations.

Side mounting

Auxiliary contact block

Single pole (1NO+1NC)

Separate mounting

Off-delay release unit

This industrial relay can be held in closed position even when the instantaneous power failure occurs.

Easy modular system

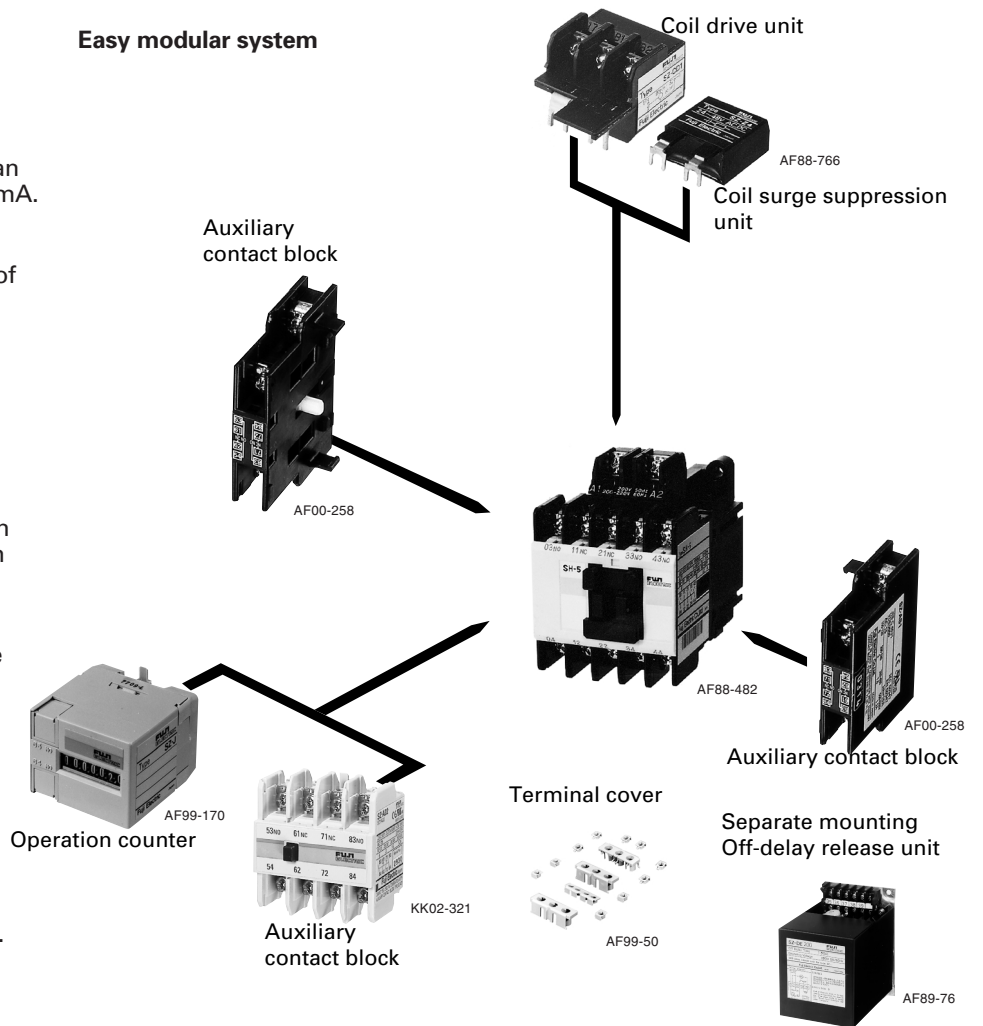

Description		Type	Ordering code	Description		Type	Ordering code	
Auxiliary contact block	For SH-4, SH-5			Terminal cover	For SH-4, SH-4H	SZ-T1	SZ1T1	
	Front mounting (Bifurcated)				For SH-5, SH-5H	SZ-T2	SZ1T2	
	4NO	SZ-A40	SZ1A40		For front mounting contact block			
	3NO+1NC	SZ-A31	SZ1A31		4-pole	SZ-T5	SZ1T5	
	2NO+2NC	SZ-A22	SZ1A22		2-pole	SZ-T6	SZ1T6	
	2NO	SZ-A20	SZ1A20		For side mounting contact block			
	1NO+1NC	SZ-A11	SZ1A11		1-pole	SZ-T7	SZ1T7	
	2NC	SZ-A02	SZ1A02	Coil drive unit	24V DC Relay contact	SZ-CD1	SZ1CD1	
	1NO+1NC *	SZ-A111	SZ1A111		Solid-state contact	SZ-03/CD2-24	SZ103CD224	
	2NO+2NC *	SZ-A222	SZ1A222		Coil surge suppression unit	Varistor 24-48V AC/DC	SZ-Z1	SZ1Z1
	Front mounting (Single button)					100-250V AC/DC	SZ-Z2	SZ1Z2
	4NO	SZ-A40H	SZ1A40H			380-440V AC/DC	SZ-Z3	SZ1Z3
	3NO+1NC	SZ-A31H	SZ1A31H			24-48V AC/DC with LED	SZ-Z6	SZ1Z6
2NO+2NC	SZ-A22H	SZ1A22H	100-240V AC/DC with LED	SZ-Z7		SZ1Z7		
Side mounting (Bifurcated)			C-R	24-48V AC/DC	SZ-Z4	SZ1Z4		
1NO+1NC	SZ-AS1	SZ1AS1		100-250V AC/DC	SZ-Z5	SZ1Z5		
Side mounting (Single button)				24-48V AC/DC with LED	SZ-Z8	SZ1Z8		
1NO+1NC	SZ-AS1H	SZ1AS1H		100-240V AC/DC with LED	SZ-Z9	SZ1Z9		
Operation counter	Without alarm contact	SZ-J	SZ1J	Off-delay release unit	100V AC 50/60Hz	SZ-DE100	SZ1DE100	
	With alarm contact				110V AC 50/60Hz	SZ-DE110	SZ1DE110	
	At 1-million operations	SZ-J1	SZ1J1		200V AC 50/60Hz	SZ-DE200	SZ1DE200	
	At 2-million operations	SZ-J2	SZ1J2		220V AC 50/60Hz	SZ-DE220	SZ1DE220	
	At 3-million operations	SZ-J3	SZ1J3		Up to 240V AC available			
	At 4-million operations	SZ-J4	SZ1J4	Live section cover	For SH-4, SH-4H	SZ-JC1	SZ1JC1	
	At 5-million operations	SZ-J5	SZ1J5		For SH-5, SH-5H	SZ-JC2	SZ1JC2	
	At 6-million operations	SZ-J6	SZ1J6					
At 7-million operations	SZ-J7	SZ1J7						
At 8-million operations	SZ-J8	SZ1J8						

Note: * Overlapping contact

Standard type industrial relays

■ Description

They are compact and highly efficient and have a long service life, and are suited for industrial electrical control applications. Typical applications include machine tools, process lines, conveyors and automatic and semi-automatic equipment.

The maximum contact ratings are 550 volts AC and 220 volts DC. Operating coils with rating of up to 600 volts AC are available.

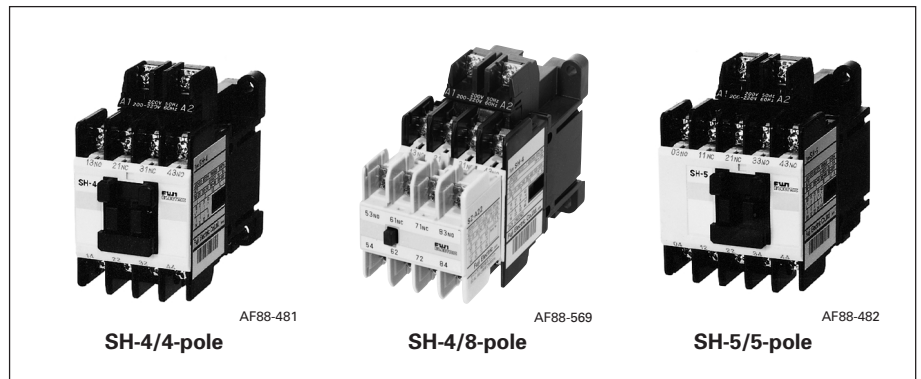

■ Features

- Mounting compatible with conventional SRC50 series industrial relays
- Employing of bifurcated contact to increase high contact reliability in low-level circuit use (5V, 3mA) and single button auxiliary contact applicable for large current circuit use.
- Variety of optional function units available
 - Auxiliary contact block (1, 2 or 4-pole)
 - Off-delay release unit
 - Coil surge suppression unit
 - Operation counter
- Snap-on 35mm IEC and DIN rail mounting available
- Meets JIS, IEC, BS, NEMA and VDE Standards
UL, CSA, TÜV, CCC, BV and LR approved
- Terminal numbers meet IEC

■ Contact ratings

Type	Ordering code *2	Contact	Pole	Rated thermal current (A)	Make and break capacity AC (A)	Rated operational current (A)					
						AC Voltage (V)	Ind. AC-15	Res. AC-12	DC Voltage (V)	Ind. *1 DC-13	Res. DC-12
SH-4	SH04AA-■□	Bifurcated contact	4 8	10	60 30 15 12	110	6	10	24	3	5
						220	3	8	48	1.5	3
						440	1.5	5	110	0.55	2.5
						550	1.2	5	220	0.27	1
SH-5	SH05AA-■□	Bifurcated contact	5	10	60 30 15 12	110	6	10	24	3	5
						220	3	8	48	1.5	3
						440	1.5	5	110	0.55	2.5
						550	1.2	5	220	0.27	1
SH-4H	SH04AH-■□	Single contact	4 8	10	60 60 40 40	110	6	10	24	5	10
						220	6	10	48	1.5	5
						440	4	10	110	0.7	4
						550	4	10	220	0.27	1
SH-5H	SH05AH-■□	Single contact	5	10	60 60 40 40	110	6	10	24	5	10
						220	6	10	48	1.5	5
						440	4	10	110	0.7	4
						550	4	10	220	0.27	1

Notes: *1 Time constant is less than 70ms.

*2 Enter the coil voltage code in the ■ mark.

Enter the contact arrangement code in the □ mark.

• 8-pole type SH-4(H) is a combination of 4-pole type SH-4(H) and add-on auxiliary contact block SZ-A□(H).

■ Coil voltage

Type	Operating coil voltage *1	Coil voltage code *2	Operating voltage range	Wiring
SH-4 SH-5	24V 50Hz/24 to 26V 60Hz 48V 50Hz/48 to 52V 60Hz	E F	0.85 to 1.1 times coil rated voltage	
SH-4H SH-5H	100V 50Hz/100 to 110V 60Hz 110 to 120V 50Hz/120 to 130V 60Hz	1 K		
	200V 50Hz/200 to 220V 60Hz 220 to 240V 50Hz/240 to 260V 60Hz	2 P		
	346 to 380V 50Hz/380 to 420V 60Hz 380 to 400V 50Hz/400 to 440V 60Hz 415 to 440V 50Hz/440 to 480V 60Hz 480 to 500V 50Hz/500 to 550V 60Hz	S 4 T 5		

Notes: *1 Other voltages between 24V and 600V AC are available on request.

*2 When ordering, specify the coil voltage code.

Industrial Relays

SH series

Standard type

■ Coil characteristics

Type	Pole	Power consumption		Pick-up voltage (V)		Drop-out voltage (V)		Watt loss (W)	
		Inrush (VA)	Sealed (VA)	200V 50Hz	220V 60Hz	200V 50Hz	220V 60Hz	200V 50Hz	220V 60Hz
SH-4, 4H	4	95	9	105-125	116-136	70-98	80-110	2.7	2.8
SH-4, 4H	8	95	9	105-125	116-136	70-98	80-110	2.7	2.8
SH-5, 5H	5	95	9	105-125	116-136	70-98	80-110	2.7	2.8

Note: Coil rating 200V 50Hz/200-220V 60Hz

■ Operating characteristics

Type	Pole	Contact arrangement	Voltage (V)	Frequency (Hz)	Pick-up time(ms.)		Drop-out time(ms.)	
					NO contact ON	NC contact OFF	NO contact OFF	NC contact ON
SH-4, 4H	4	2NO+2NC	200	50	9-20	5-15	5-15	9-20
SH-4, 4H	8	4NO+4NC	200	50	9-20	5-15	5-15	9-20
SH-5, 5H	5	3NO+2NC	200	50	9-20	5-15	5-15	9-20

Note: Coil rating 200V 50Hz/200-220V 60Hz

■ Performance data (AC-15)

Type	Pole	Making current	Breaking current	Operating cycles per hour	Voltage	Life expectancy(operations)	
						Electrical	Mechanical
SH-4, 4H	4	10 le	1 le	1800	220V/440V	500,000	10 million
SH-4, 4H	8	10 le	1 le	1800	220V/440V	500,000	10 million
SH-5, 5H	5	10 le	1 le	1800	220V/440V	500,000	10 million

Note: le: Rated operational current (A)

■ Combination of industrial relay and auxiliary contact block

The standard type industrial relays can be used according to the combination with the auxiliary contact blocks shown below.

Industrial relay		Add-on auxiliary contact block						Side mounting	
Bifurcated contacts		Front mounting						SZ-AS1x2	
Type	Contact arrangement	SZ-A40	SZ-A31	SZ-A22	SZ-A20	SZ-A11	SZ-A02	SZ-AS1	SZ-AS1
		4NO	3NO+1NC	2NO+2NC	2NO	1NO+1NC	2NC	2NO+2NC	1NO+1NC
SH-4	4NO	8NO	7NO+1NC	6NO+2NC	6NO	5NO+1NC	4NO+2NC	6NO+2NC	5NO+1NC
	3NO+1NC	7NO+1NC	6NO+2NC	5NO+3NC	5NO+1NC	4NO+2NC	3NO+3NC	5NO+3NC	4NO+2NC
	2NO+2NC	6NO+2NC	5NO+3NC	4NO+4NC	4NO+2NC	3NO+3NC	2NO+4NC	4NO+4NC	3NO+3NC
	8NO	-	-	-	-	-	-	-	-
	7NO+1NC	-	-	-	-	-	-	-	-
	6NO+2NC	-	-	-	-	-	-	-	-
	5NO+3NC	-	-	-	-	-	-	-	-
4NO+4NC	-	-	-	-	-	-	-	-	
SH-5	5NO	9NO	8NO+1NC	7NO+2NC	7NO	6NO+1NC	5NO+2NC	7NO+2NC	6NO+1NC
	4NO+1NC	8NO+1NC	7NO+2NC	6NO+3NC	6NO+1NC	5NO+2NC	4NO+3NC	6NO+3NC	5NO+2NC
	3NO+2NC	7NO+2NC	6NO+3NC	5NO+4NC	5NO+2NC	4NO+3NC	3NO+4NC	5NO+4NC	4NO+3NC
	2NO+3NC	6NO+3NC	5NO+4NC	-	4NO+3NC	3NO+4NC	-	-	3NO+4NC
	1NO+4NC	5NO+4NC	-	-	3NO+4NC	-	-	-	-
	5NC	4NO+5NC	-	-	2NO+5NC	-	-	-	-

Industrial relay		Add-on auxiliary contact block		
Single contact		Front mounting		
Type	Contact arrangement	SZ-A40H	SZ-A31H	SZ-A22H
		4NO	3NO+1NC	2NO+2NC
SH-4H	4NO	8NO	7NO+1NC	6NO+2NC
	3NO+1NC	-	-	-
	2NO+2NC	-	5NO+3NC	4NO+4NC
SH-5H	5NO	9NO	8NO+1NC	7NO+2NC
	4NO+1NC	-	-	-
	3NO+2NC	-	6NO+3NC	5NO+4NC
	2NO+3NC	-	-	-
	1NO+4NC	-	-	-
	5NC	4NO+5NC	-	-

Notes:

- Both front mounting and side mounting auxiliary contact blocks cannot be mounted on a relay at a time.
- Any auxiliary contact blocks cannot be mounted on 8-pole type SH-4 and SH-4H relays.
- Side mounting contact blocks (SZ-AS1), with bifurcated contacts, can be mounted on SH-4H and SH-5H.

■ Ordering information

Specify the following:

1. Ordering code

■ Dimensions, mm
SH-4, 4H/4-pole

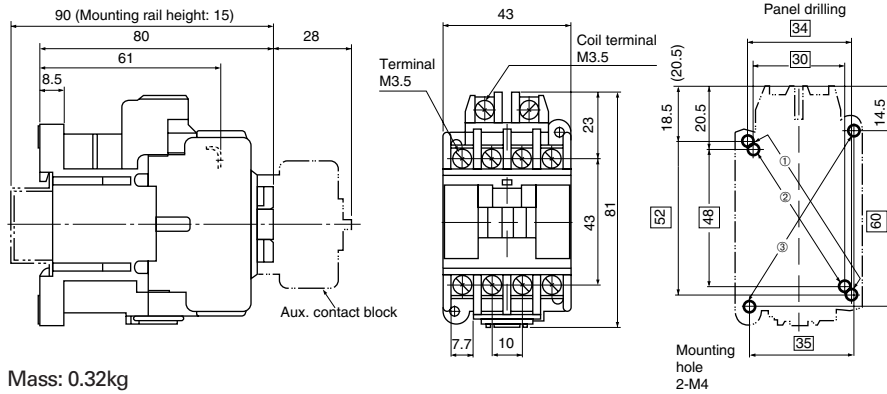

Mass: 0.32kg

■ Contact arrangement

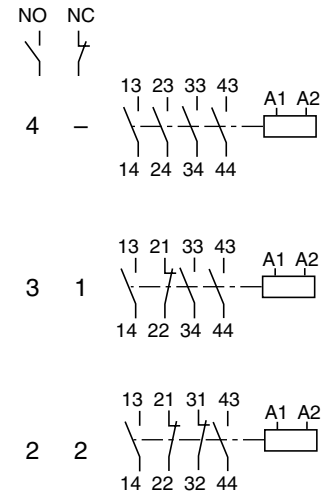

SH-4, 4H/8-pole

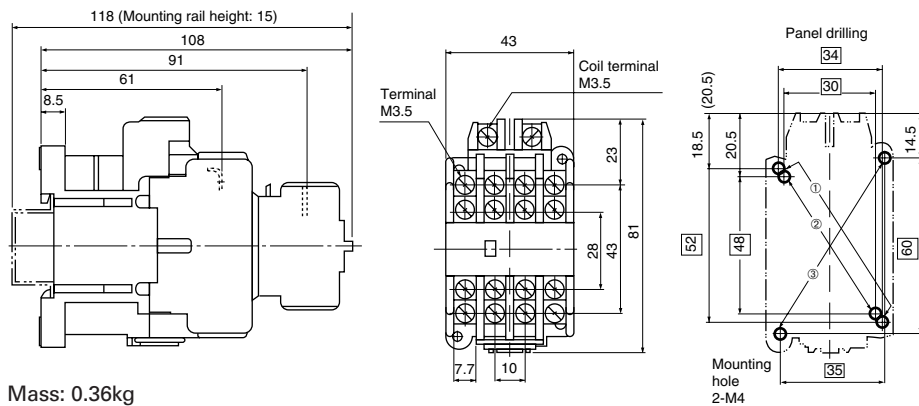

Mass: 0.36kg

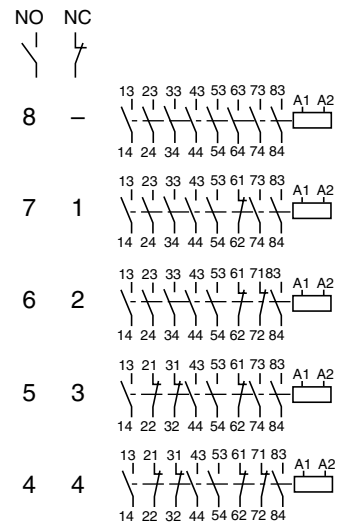

SH-5, 5H/5-pole

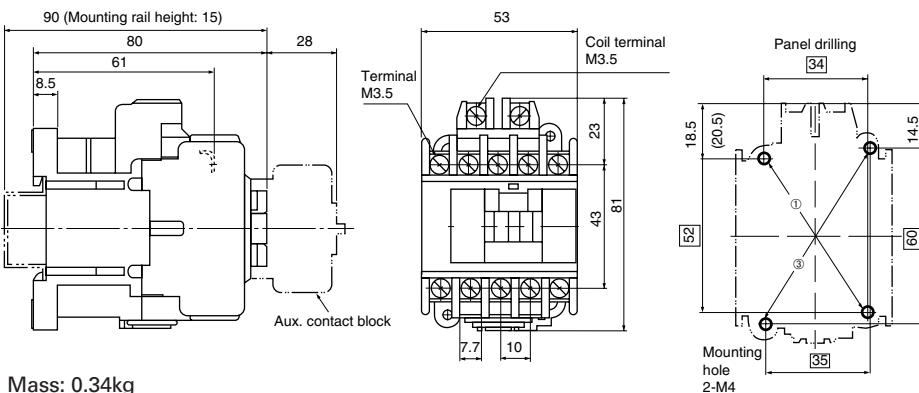

Mass: 0.34kg

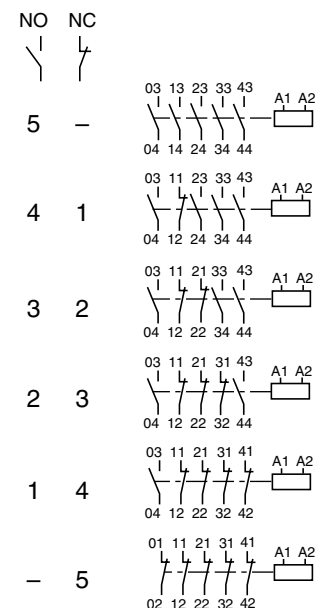

- Notes on panel drilling
- Use the two mounting holes on a diagonal line to mount a relay.
 - Mounting holes indicated by ① and ② are compatible with those of SRC type.
 - Mounting holes indicated by ③ conform to IEC Standards.

Industrial Relays

SH series

DC-operated type

DC-operated industrial relays

■ Description

The operating coil is a DC type instead of AC and is energized by a DC power source.

The coil ratings from 24V DC to 220V DC. The maximum contact ratings are 550V AC or 220V DC.

These relays are typically used where DC is used as a power source on switchboards. Where AC is used as a power source, sequence control is frequently lost due to the troubles such as power failure or momentary voltage drop.

In the case of DC-control, a battery power supply is frequently used because it is not susceptible to external influences. DC-operated relays are highly suitable for important control applications.

■ Features

- Employing of bifurcated contact to increase high contact reliability in low-level circuit use (5V, 3mA)
- Variety of optional function units available

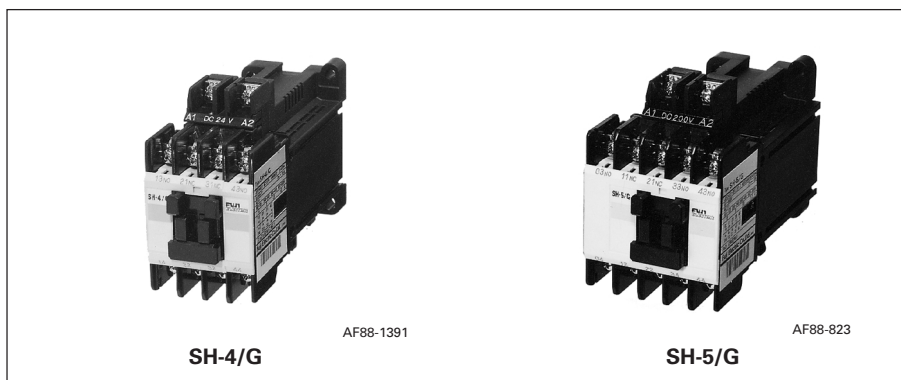

- Auxiliary contact block (1, 2 or 4-pole)
- Coil surge suppression unit
- Operation counter
- Snap-on 35mm IEC and DIN rail mountings available
- Meets JIS, IEC, BS, NEMA and VDE Standards
- UL, CSA, TÜV, CCC and BV approved
- Terminal numbers meet IEC

■ Performance data

- Mechanical durability: 10 million operations
- Electrical durability: 500,000 operations (at AC-15 rated operational current)
- Operating cycles per hour: 1800
- Allowable ambient temp.: -5° to +50°C

■ Contact ratings

Type	Ordering code *2	Pole	Rated thermal current (A)	Make and break capacity AC (A)	Rated operational current (A)			DC Voltage (V)	Ind. *1 DC-13	Res. DC-14
					AC Voltage (V)	Ind. AC-15	Res. AC-12			
SH-4/G	SH04AG-■□	4	10	60	110	6	10	24	3	5
				30	220	3	8	48	1.5	3
				15	440	1.5	5	110	0.55	2.5
				12	550	1.2	5	220	0.27	1
SH-5/G	SH05AG-■□	5	10	60	110	6	10	24	3	5
				30	220	3	8	48	1.5	3
				15	440	1.5	5	110	0.55	2.5
				12	550	1.2	5	220	0.27	1

Notes: *1 Time constant is less than 70ms.

*2 Enter the coil voltage code in the ■ mark.

Enter the contact arrangement code in the □ mark.

■ Coil ratings

Type	Pole	Contact arrangement	Operating coil voltage (V DC)	Code	Power consumption(W)
SH-4/G	4	4NO, 3NO+1NC, 2NO+2NC	24	E	7
			48	F	
			100	1	
			110	H	
SH-5/G	5	5NO, 4NO+1NC, 3NO+2NC 2NO+3NC, 1NO+4NC, 5NC	200	2	
			220	M	

■ Ordering information

Specify the following:
1. Ordering code

■ Combination with auxiliary contact blocks

Same as standard type.
See page 03/4.

■ Operating characteristics

Type	Pole	Contact arrangement	Voltage	Pick-up time (ms.)		Drop-out time (ms.)	
				NO contact ON	NC contact OFF	NO contact OFF	NC contact ON
SH-4/G	4	2NO+2NC	100V DC	45-50	35-40	20-25	25-30
	8	4NO+4NC	100V DC	45-50	35-40	20-25	25-30
SH-5/G	5	3NO+2NC	100V DC	45-50	35-40	20-25	25-30

Note: Coil rating 100V DC

■ Dimensions, mm

SH-4/G, 4-pole

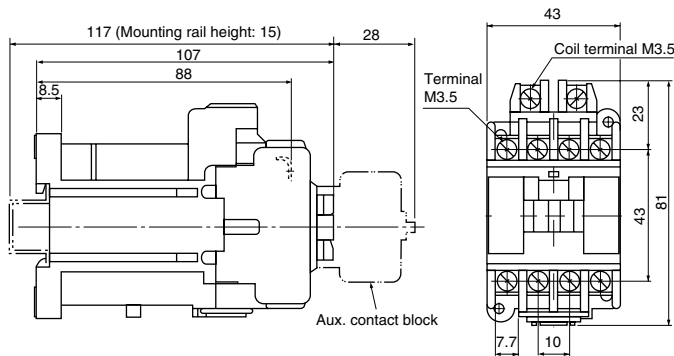

Mass: 0.55kg

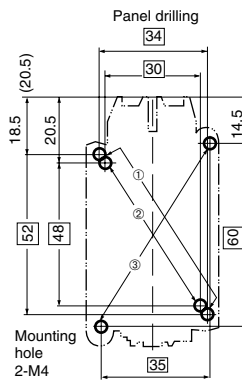

■ Contact arrangement

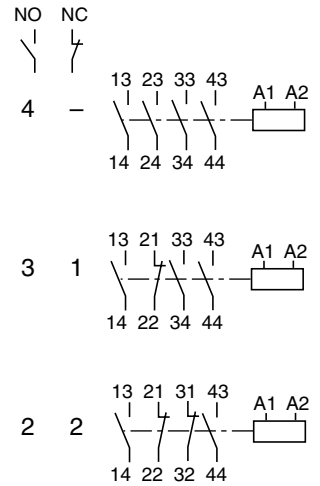

SH-4/G, 8-pole

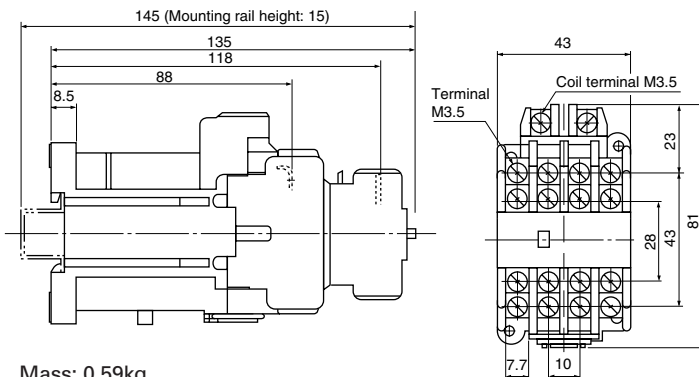

Mass: 0.59kg

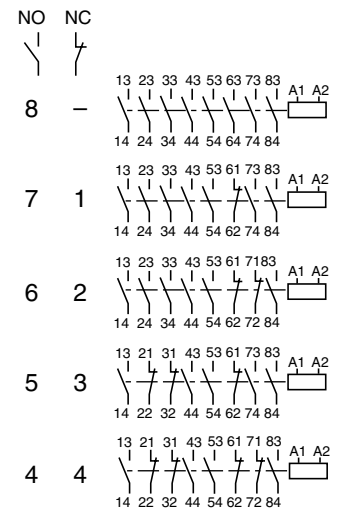
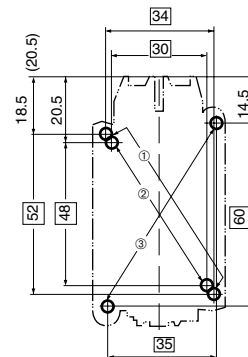

SH-5/G, 5-pole

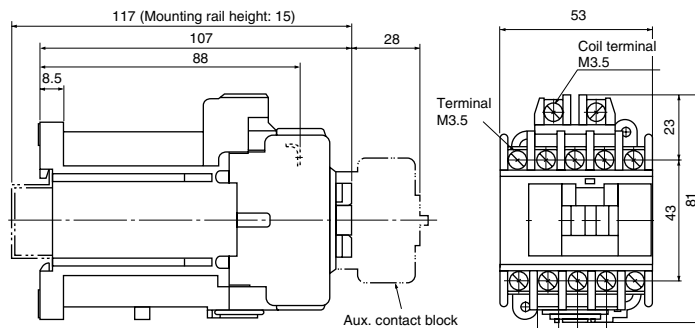

Mass: 0.58kg

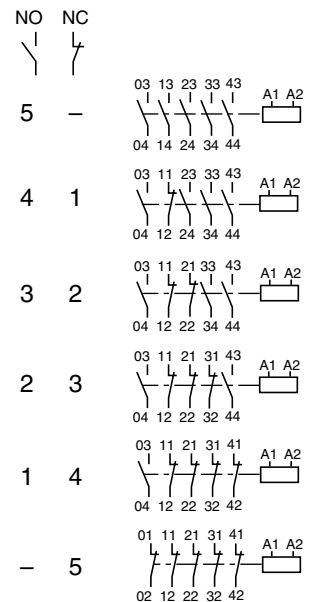
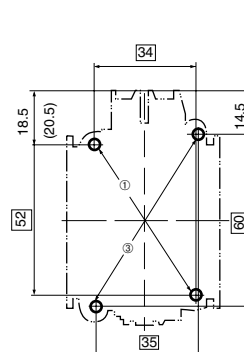

Notes on panel drilling
 • Use the two mounting holes on a diagonal line to mount a relay.
 • Mounting holes indicated by ① and ② are compatible with those of SRC type.
 • Mounting holes indicated by ③ conform to IEC Standards.

Industrial Relays

SH series

UL and CSA approved

UL and CSA approved



■ Types and ratings

● AC operated

Type	Ordering code	Pole	Continuous current (A)	Rated operational current (A)						Rating code		Contact arrangement	Operating coil
				AC			DC			AC	DC		
				Volts	Make	Break	Volts	Make	Break				
SH-4	SH04AA-■□	4	10	120	60	6	125	0.55	0.55	A600	Q300	4NO 3NO+1NC 2NO+2NC	Available for 24V to 600V AC 50/60Hz
				240	30	3	250	0.27	0.27				
		8	10	120	60	6	125	0.55	0.55	A600	Q300	8NO, 7NO+1NC 6NO+2NC 5NO+3NC 4NO+4NC	
				240	30	3	250	0.27	0.27				
SH-5	SH05AA-■□	5	10	120	60	6	125	0.55	0.55	A600	Q300	5NO, 4NO+1NC 3NO+2NC 2NO+3NC 1NO+4NC, 5NO	
				240	30	3	250	0.27	0.27				
				480	15	1.5							
				600	12	1.2							

Notes: • SH-4 type with 8-pole is a combination of SH-4 type industrial relay with 4-pole and SZ-A□ (Front mounting) type auxiliary contact block with 4-pole.

• Enter the coil voltage code in the ■ mark. See page 03/1.

Enter the contact arrangement code in the □ mark. See page 03/1.

● DC operated

Type	Ordering code	Pole	Continuous current (A)	Rated operational current (A)						Rating code		Contact arrangement	Operating coil
				AC			DC			AC	DC		
				Volts	Make	Break	Volts	Make	Break				
SH-4/G	SH04AG-■□	4	10	120	60	6	125	0.55	0.55	A600	Q300	4NO 3NO+1NC 2NO+2NC	Available for 24V to 220V DC
				240	30	3	250	0.27	0.27				
		8	10	120	60	6	125	0.55	0.55	A600	Q300	8NO, 7NO+1NC 6NO+2NC 5NO+3NC 4NO+4NC	
				240	30	3	250	0.27	0.27				
SH-5/G	SH05AG-■□	5	10	120	60	6	125	0.55	0.55	A600	Q300	5NO, 4NO+1NC 3NO+2NC 2NO+3NC 1NO+4NC, 5NC	
				240	30	3	250	0.27	0.27				
				480	15	1.5							
				600	12	1.2							

Notes: • SH-4/G type with 8-pole is a combination of SH-4/G type industrial relay with 4-pole and SZ-A□ (Front mounting) type auxiliary contact block with 4-pole.

• Enter the coil voltage code in the ■ mark.

Enter the contact arrangement code in the □ mark.

■ Ordering information

Specify the following:

1. Ordering code

■ Dimensions

Same as standard type industrial relay.

See page 03/5 and 03/7.

■ Combination with auxiliary contact blocks

Same as standard type.

See page 03/4.

TÜV and CCC approved

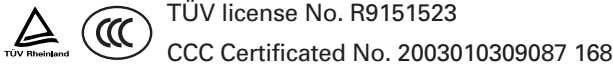

Types and ratings

● AC operated, bifurcated contact

Type	Ordering code *2	Contact	Pole	Rated thermal current (A)	Make and break capacity AC (A)	Rated operational current (A)					
						AC Voltage (V)	Ind. AC-15	Res. AC-12	DC Voltage (V)	Ind. *1 DC-13	Res. DC-12
SH-4	SH04AA-■□	Bifurcated contact	4 8	10	60 30 15 12	110	6	10	24	3	5
						220	3	8	48	1.5	3
						440	1.5	5	110	0.55	2.5
						550	1.2	5	220	0.27	1
SH-5	SH05AA-■□	Bifurcated contact	5	10	60 30 15 12	110	6	10	24	3	5
						220	3	8	48	1.5	3
						440	1.5	5	110	0.55	2.5
						550	1.2	5	220	0.27	1

Notes: *1 Time constant is less than 70ms.
*2 Enter the coil voltage code in the ■ mark.
Enter the contact arrangement code in the □ mark.
• 8-pole type SH-4(H) is a combination of 4-pole type SH-4(H) and add-on auxiliary contact block SZ-A□(H).

● DC operated

Type	Ordering code *2	Pole	Rated thermal current (A)	Make and break capacity AC (A)	Rated operational current (A)					
					AC Voltage (V)	Ind. AC-15	Res. AC-12	DC Voltage (V)	Ind. *1 DC-13	Res. DC-14
SH-4/G	SH04AG-■□	4 8	10	60 30 15 12	110	6	10	24	3	5
					220	3	8	48	1.5	3
					440	1.5	5	110	0.55	2.5
					550	1.2	5	220	0.27	1
SH-5/G	SH05AG-■□	5	10	60 30 15 12	110	6	10	24	3	5
					220	3	8	48	1.5	3
					440	1.5	5	110	0.55	2.5
					550	1.2	5	220	0.27	1

Notes: *1 Time constant is less than 70ms.
*2 Enter the coil voltage code in the ■ mark.
Enter the contact arrangement code in the □ mark.

CCC approved

● AC operated, single contact

Type	Certificate No.
SH-4H SH-5H	2003010309087168

● With extra pick-up operating coil

Type	Certificate No.
SH-4/U SH-5/U	2003010309087168

■ Ordering information

Specify the following:
1. Ordering code
2. CCC approved

● Auxiliary contact blocks/optional

Description	Type	Applicable type	Certificate No.
Front mounting, bifurcated	SZ-A40 SZ-A31 SZ-A22 SZ-A20 SZ-A11 SZ-A02	SH-4, SH-5	Certified according to an applicable industrial type
Front mounting, single button	SZ-A40H SZ-A31H SZ-A22H	SH-4, SH-5	
Side mounting, bifurcated	SZ-AS1	SH-4, SH-5	
Side mounting, single button	SZ-AS1H	SH-4, SH-5	

Industrial Relays

SH series

Off-delay release type

Off-delay release industrial relays

■ Description

This type of control relay has a capacitor connected in parallel with the operating coil, and the contacts are released with a delay of 1 to 5 seconds after the coil has been de-energized. If a momentary voltage drop or a power failure in AC control power supply of standard type control relay takes place, the operating coils are de-energized. Reclosing of the contacts must be carried out every time. The off-delay release relay is so designed that in the event of a brief power outage the coil will not release the contacts and control sequence is maintained.

■ Operation

The power supply is fed to the rectifier which in turn charges the capacitor. When a power failure takes place, the discharge current flows into the magnetic coil which holds the relay closed for 1 to 5 seconds. When the switch (SW) is opened the contacts will immediately open without delay.

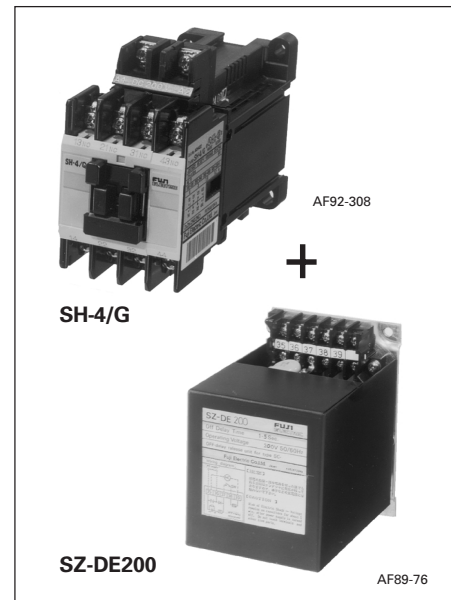
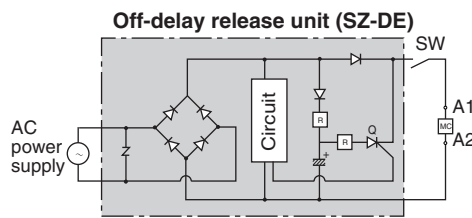

■ Types and ordering codes

Type Contactor	Off-delay release unit	Ordering code Contactor	Off-delay release unit	Contact arrangement	Rated thermal current (A)	Make and break capacity at AC (A)
SH-4/G	SZ-DE100	SH04AG-■ □	SZ1DE100	4NO, 3NO+1NC, 2NO+2NC	10	66
	SZ-DE110		SZ1DE110			33
	SZ-DE200		SZ1DE200	8NO, 7NO+1NC, 6NO+2NC		16.5
	SZ-DE220		SZ1DE220	5NO+3NO, 4NO+4NC		13.2
SH-5/G	SZ-DE100	SH05AG-■ □	SZ1DE100	5NO, 4NO+1NC, 3NO+2NC	10	66
	SZ-DE110		SZ1DE110			33
	SZ-DE200		SZ1DE200	2NO+3NC, 1NO+4NC, 5NC		16.5
	SZ-DE220		SZ1DE220	5NC		13.2

Notes: • Enter the coil voltage code in the ■ mark.
 • Enter the contact arrangement code in the □ mark.
 • Rated operational current: Same as DC-operated type. See page 03/6.

■ Performance data

Type	Hold time	Operating cycles per hour	Capacitor life
SH-4/G+SZ-DE□ SH-5/G+SZ-DE□	1 to 5 sec.	600	100,000 operations

■ Operating voltage and frequency

● Magnetic coil

Type	Voltage	Code
SH-4/G	100V DC	1
SH-5/G	110V DC	H
	200V DC	2
	220V DC	M

● OFF-delay release unit

Type	Input voltage
SZ-DE100	100V AC 50/60Hz
SZ-DE110	110V AC 50/60Hz
SZ-DE200	200V AC 50/60Hz
SZ-DE220	220V AC 50/60Hz

■ Combination with auxiliary contact blocks

Same as standard type.
See page 03/4.

■ Dimensions, mm

● Off-delay release unit

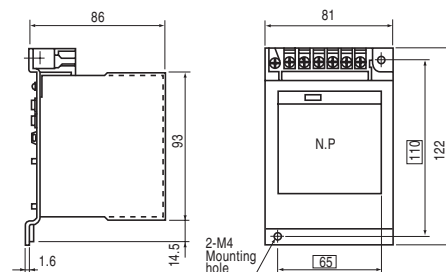

Mass: 0.85kg

● Industrial relay:

See page 03/7, DC-operated industrial relay

■ Wiring diagram

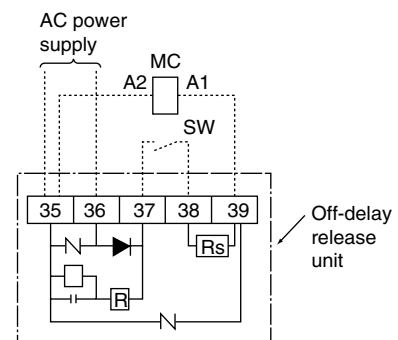

■ Ordering information

Specify the following:
1. Ordering code

Note:

When ordering, make sure that the input voltage (AC) of the OFF-delay release unit is equal to the operating voltage (DC) of the industrial relay.

Example:

SZ-DE 100V AC 50Hz+SH-5/G 100V DC
(OFF-delay release unit)+(Relay)

Mechanical latch industrial relays

■ **Description**

Mechanical latch relays are used where operating sequence continuity must be maintained regardless of any outside interruptions, such as power failures or momentary voltage drop. These relays are provided with two coils.

One is a closing coil (CC) and the other is a tripping coil (TC). An interlocking circuit is provided between the CC coil and TC coil. Since no coil voltage is applied during operation it is extremely economical and also quiet.

■ **Operating method**

● **Closing**

When the closing coil is energized the latch mechanism interlocks to latch and the NC contact connected in series with the closing coil opens and the coil is de-energized.

■ **Operating notes**

- When carrying out a sequence operating check make sure that the load is disconnected.
- The electrical signal time for closing and tripping should be 0.3 sec. or more.
- Both the closing and tripping coils are short time rating.
Closing coil: Max. 30 seconds
Tripping coil: Max. 15 seconds
- Since the relay and the latch mechanisms are adjusted at the time of assembly, do not strip nor replace the contacts in the field.
- If current is applied simultaneously to both the closing and tripping circuits, the coils may be heated and damaged. An interlocking circuit is required to prevent this.

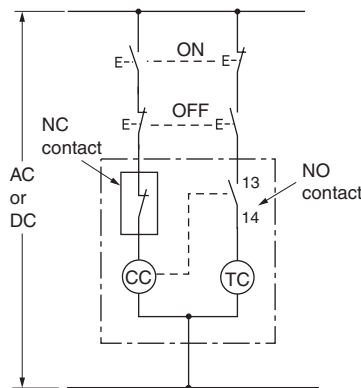

● **Tripping**

When the tripping coil is energized the latch is released and tripping is carried out by means of the back spring. At this time the NO contact connected in series with the tripping coil opens.

■ **Performance data**

- Mechanical durability: 1 million operations
- Electrical durability: 500,000 operations (at AC-15 rated operational current)
- Operating cycles per hour: 1200
- Allowable ambient temp.: -5°C to +50°C

■ **Ordering information**

Specify the following:

1. Ordering code

Notes:

1. Mechanical latch units cannot be sold separately.
2. Do not detach mechanical latch units from relays and do not make modifications such as attaching mechanical latch units to other industrial relays.

■ **Types and ordering code**

AC operated Type	Ordering code	DC operated Type	Ordering code	Contact arrangement	Rated thermal current (A)	Make/break capacity AC (A)
SH-4/V	SH04AV-■□	SH-4/VG	SH04AD-■□	3NO, 2NO+1NC, 1NO+2NC	10	60
				5NO+2NC, 4NO+3NC, 3NO+4NC		30
SH-5/V	SH05AV-■□	SH-5/VG	SH05AD-■□	4NO, 3NO+1NC, 2NO+2NC	10	15
						12

Notes: • Enter the coil voltage code in the ■ mark.
Enter the contact arrangement code in the □ mark.
• Rated operational current: Same as standard type, see page 03/3.

■ **Coil ratings**

Type	Operating coil Voltage	Code	Power consumption		Minimum energized time	Time rating		Operating voltage range
			AC operated Closing	AC operated Tripping		DC operated Closing	DC operated Tripping	
SH-4/V	100V/100-110V AC 50Hz/60Hz	1	95VA	150VA	0.3 sec.	30 sec.	15 sec.	0.85 to 1.1 times coil rated voltage
SH-5/V	200V/200-220V AC 50Hz/60Hz	2						
SH-4/VG	100V DC	1						
SH-5/VG	110V DC	H						
	200V DC	2						
	220V DC	M						

Note: Coil voltage range from 24V to 220V AC and 24V to 220V DC is available.

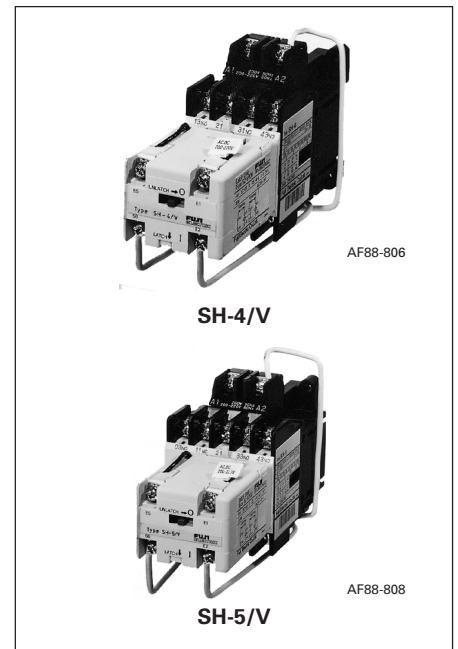

■ **Manual operating sequence**

Closing: Press the button in the direction of the arrow.

Tripping: Push the lever in the direction of the arrow.

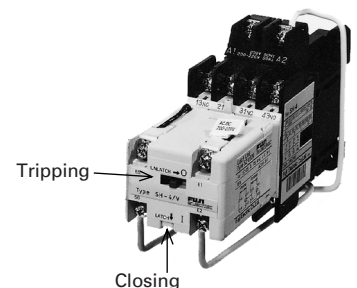

Industrial Relays

SH series

Mechanical latch type

■ Dimensions, mm

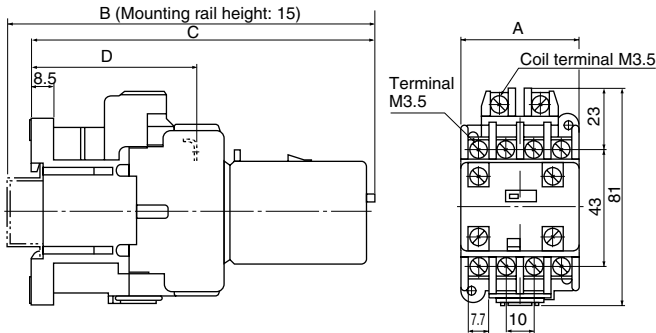

Panel drilling SH-4/V, VG

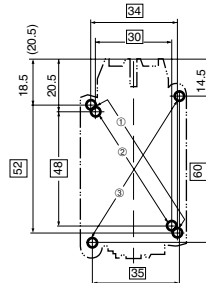

SH-5/V, VG

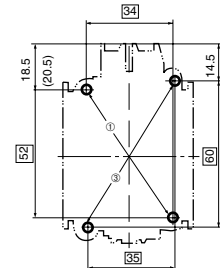

Type	No. of contact	A	B	C	D	Mass (kg)
SH-4/V	3	43	138	128	61	0.42
SH-4/V	7	67	138	128	61	0.47
SH-5/V	4	53	138	128	61	0.44
SH-4/VG	3	43	165	155	88	0.66
SH-4/VG	7	67	165	155	88	0.72
SH-5/VG	4	53	165	155	88	0.69

Note on panel drilling

- Use the two mounting holes on a diagonal line to mount a relay.
- Mounting holes indicated by ① and ② are compatible with those of SRC type.
- Mounting holes indicated by ③ conform to IEC Standards.

■ Wiring diagrams

SH-4/V, SH-4/VG (3-contact) 3NO

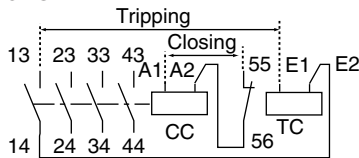

SH-4/V, SH-4/VG (7-contact) 5NO+2NC

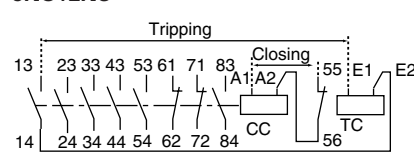

SH-5/V, SH-5/VG 4NO

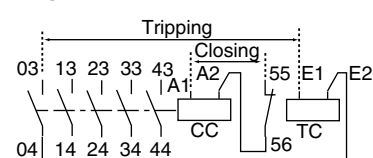

2NO+1NC

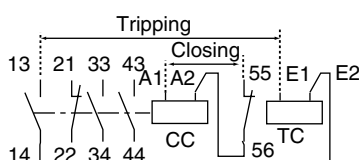

4NO+3NC

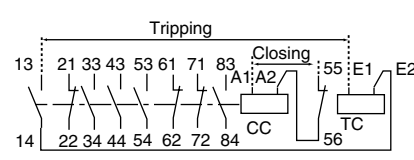

3NO+1NC

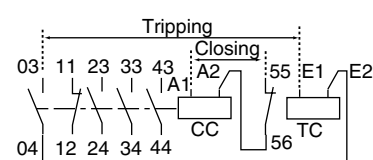

1NO+2NC

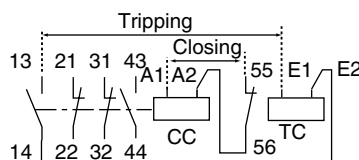

3NO+4NC

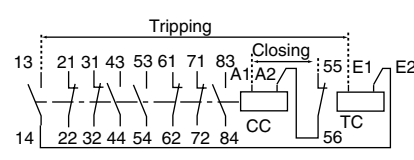

2NO+2NC

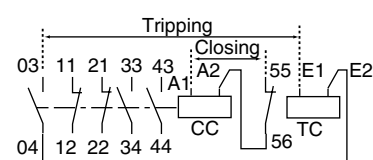

CC: Closing coil
TC: Tripping coil

■ Combination of industrial relay and auxiliary contact block

The mechanical latch industrial relays can be used according to the combination with the side mounting auxiliary contact blocks as shown on the right.

Mechanical latch industrial relay Type	Contact arrangement	Auxiliary contact block (Side mounting) SZ-AS1Vx2	SZ-AS1V
SH-4/V	3NO	5NO+2NC	4NO+1NC
SH-4/VG	2NO+1NC	4NO+3NC	3NO+2NC
	1NO+2NC	3NO+4NC	2NO+3NC
	5NO+2NC	-	-
	4NO+3NC	-	-
	3NO+4NC	-	-
SH-5/V	4NO	6NO+2NC	5NO+1NC
SH-5/VG	3NO+1NC	5NO+3NC	4NO+2NC
	2NO+2NC	4NO+4NC	3NO+3NC

Industrial relays with extra pick-up operating coil

■ Description

Generally, ordinary control relays are designed to operate within 85–110% of the rated voltage. However, relays with extra pick-up operating coils have a wider operating range of 75–110% of their normal rated voltage. They are used where the control power source is low and occasional voltage drops can be expected. Their performance is dependable in spite of low voltage conditions. Their outer dimensions and performance are similar to the standard type relay. They have a mechanical durability of 2.5 million operations.

■ Ordering information

Specify the following:
1. Ordering code

■ Performance data

- Same as standard type. See page 03/4.
- Mechanical durability: 2.5 million operations

■ Dimensions

Same as standard type. See page 03/5.

■ Combination of contact blocks

Same as standard type. See page 03/4.



03

■ Types and ordering codes

Type	Ordering code	Pole	Contact arrangement	Rated thermal current (A)	Make and break capacity AC (A)	Rated operational current (A)					
						AC Volts	Ind. AC-15	Res. AC-12	DC Volts	Ind.* DC-13	Res. DC-12
SH-4/U	SH04AU-■□	4	4NO, 3NO+1NC 2NO+2NC	10	60 30 15 12	110 220 440 550	6 3 1.5 1.2	10 8 5 5	24 48 110 220	3 1.5 0.55 0.27	5 3 2.5 1
		8	8NO, 7NO+1NC 6NO+2NC, 5NO+3NC 5NO+3NC 4NO+4NC	10	60 30 15 12	110 220 440 550	6 3 1.5 1.2	10 8 5 5	24 48 110 220	3 1.5 0.55 0.27	5 3 2.5 1
SH-5/U	SH05AU-■□	5	5NO, 4NO+1NC 3NO+2NC, 2NO+3NC 1NO+4NC, 5NC	10	60 30 15 12	110 220 440 550	6 3 1.5 1.2	10 8 5 5	24 48 110 220	3 1.5 0.55 0.27	5 3 2.5 1

- Notes: 1. * Time constant is less than 70ms.
2. 8-pole type SH-4/U is a combination of 4-pole type SH-4/U and 4-pole auxiliary contact block SZ-A□.
3. Enter the coil voltage code in the ■ mark.
Enter the contact arrangement code in the □ mark.

■ Coil voltage

Type	Operating coil voltage	Coil voltage code	Wiring
SH-4/U SH-5/U	100V AC 50Hz/100–110V AC 60Hz	1	
	110–120V AC 50Hz/120–130V AC 60Hz	K	
	200V AC 50Hz/200–220V AC 60Hz	2	
	200–240V AC 50Hz/240–260V AC 60Hz	P	
	380–400V AC 50Hz/400–440V AC 60Hz	4	

Note: The above is the normal voltage. Other voltages between 24V and 550V AC are available on request.

■ Coil characteristics

Type	Pole	Power consumption (VA)		Watt loss (W)		Pick-up voltage		Drop-out voltage		Operating time (ms)	
		Inrush	Sealed	200V 50Hz	200V 60Hz	50Hz	60Hz	50Hz	60Hz	Coil ON→ Contact ON	Coil OFF→ Contact OFF
SH-4/U	4	120	15	4	4	93–115	102–124	58–88	66–96	9–16	6–13
	8	120	15	4	4	93–116	102–126	58–90	66–99	8–15	6–13
SH-5/U	5	120	15	4	4	93–116	102–126	58–90	66–99	9–17	6–13

Note: Coil ratings: 200V 50Hz/200–220V 60Hz
Operating time is based on 200V 50Hz

Industrial Relays

SH series

With quick terminals

Industrial relays with newly developed quick terminals

■ Description

The product and terminal structure comply with international safety standards. It complies with VGB4, DIN57106, and VDE0106 Teil 100 which are recommendation for preventing the exposure of charging current part.

Components such fork crimp terminals, and ring crimp terminals are inserted and secured by tightening the terminal screw. See Figures 1 to 3.

■ Features

- Easy wiring
Wiring time is at least 50% shorter than the conventional screw type terminal.
- Safety
The finger protection feature protects the charging current part during maintenance and check (complying with EN60947-4-1, and IEC60947-4-1)

■ Types and ordering codes

Type	Ordering code	Pole	Contact arrangement	Rated thermal current (A)
SH-4Y	SH04ZA- ■40	4	4NO	10
	SH04ZA- ■31	4	3NO+1NC	10
	SH04ZA- ■22	4	2NO+2NC	10
	SH04ZA- ■80	8*	8NO	10
	SH04ZA- ■71	8*	7NO+1NC	10
	SH04ZA- ■62	8*	6NO+2NC	10
	SH04ZA- ■53	8*	5NO+3NC	10
	SH04ZA- ■44	8*	4NO+4NC	10

Note: * 8-pole type SH-4Y is combination of 4-pole type SH-4Y and 4-pole auxiliary contact block SZ-A■
* Enter the coil voltage code in the ■ mark.

■ Dimensions, mm

SH-4Y (4-pole)

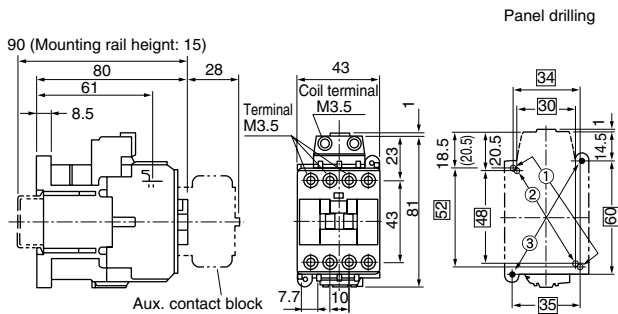

Mass: 0.32kg

■ Contact arrangement

Same as standard type.
See page 03/5.

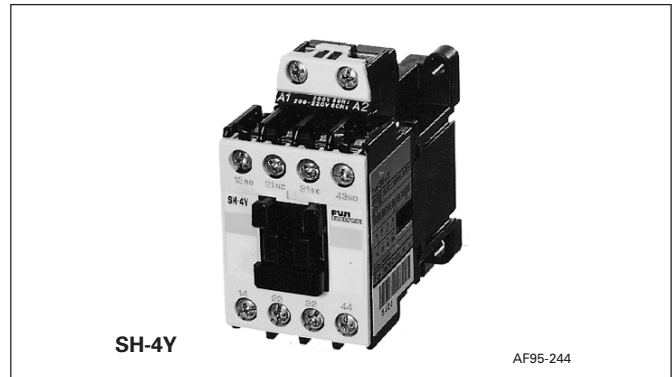

- Standard
UL, CSA and TÜV approved

When one crimp terminal is used (Fig. 2)

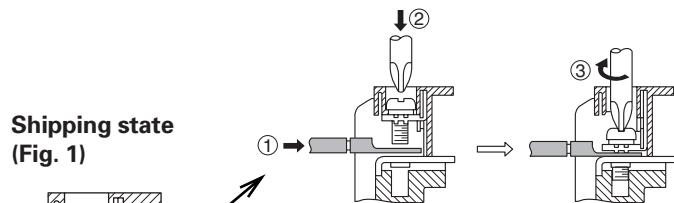

When two crimp terminals are used (Fig. 3)

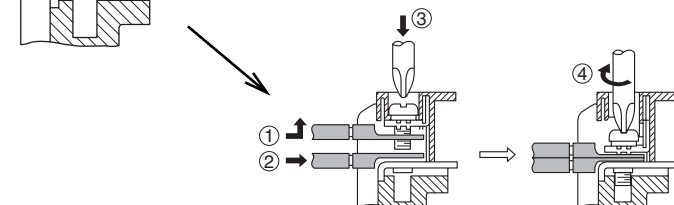

■ Ordering information

Specify the following
1. Ordering code

SH-4Y (8-pole)

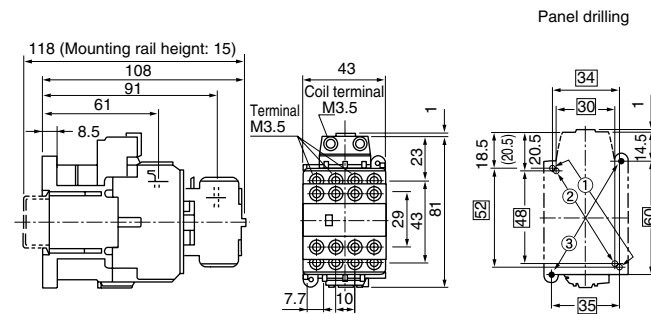

Mass: 0.36kg

Notes on panel drilling

- Use the two mounting holes on a diagonal line to mount a relay.
- Mounting holes indicated by ① and ② are compatible with those of SRC type.
- Mounting holes indicated by ③ conform to IEC Standards.