

Panel Switches

NS387 and RC310

Instrument switches

Voltmeter/Ammeter Changeover Switches

■ Description

These switches are used with voltmeters or ammeters in secondary PT or CT circuits. Normally, 3-phase line voltage or phase current is measured with 3 meters provided, which requires considerable switchboard or console space. Space can be saved by using NS387 and RC310 instrument switches, since the phase current or line voltage can be read with a single meter and either VS or AS (Voltmeter or Ammeter switch). FUJI AS's are precisely and ruggedly constructed, and open circuits do not occur at the time of switch-over, so eliminating the possibility of abnormal voltage trouble. NS387 is a

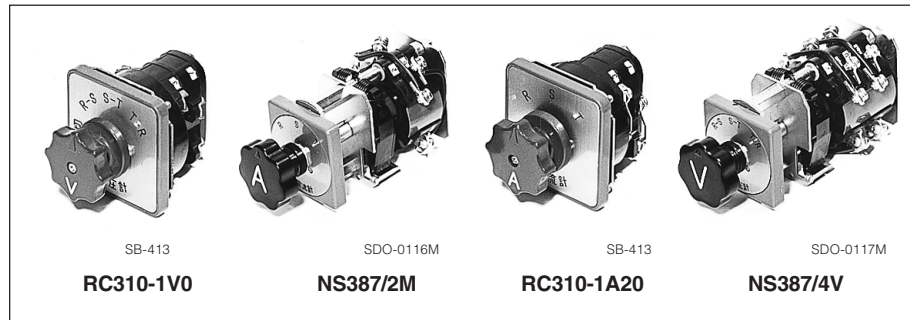

blade-type switch and RC310 is a cam-type. Both are compact in size and use highly dependable silver contacts. FUJI can also supply DC voltmeter type switches in addition to these for AC use.

■ Ordering information

Specify the following:
1. Type number

Series	Application	Type	Ordering code	No. of contact block	Legend plate *	Handle angle	With or without Off position	Mass (kg)
NS387	AC Voltmeter	NS387/4V	AC38V4N	4	R · S · S-T · T-R	2 x 45°	Without	0.5
	AC Voltmeter	NS387/4V0	AC38V4F	4	OFF · R · S · S-T · T-R	3 x 45°	With	0.5
	DC Voltmeter	NS387/2V	AC38V2N	2	I · OFF · II	2 x 45°	With	0.43
	AC Ammeter	NS387/2M	AC38A2N	2	R · S · T	2 x 45°	Without	0.43
	AC Ammeter	NS387/2M0	AC38A2F	3	OFF · R · S · T	3 x 45°	With	0.47
	AC Ammeter	NS387/3M	AC38A3N	3	R · S · T	2 x 45°	Without	0.47
	AC Ammeter	NS387/4M	AC38A43F	4	OFF · R · S · T	3 x 45°	With	0.5
RC310	AC Voltmeter	RC310-1V	AK2R1-V32	2	R · S · S-T · T-R	2 x 45°	Without	0.22
	AC Voltmeter	RC310-1V0	AK2R1-V42	2	OFF · R · S · S-T · T-R	3 x 45°	With	0.22
	AC Ammeter	RC310-1A2	AK2R1-A32	2	R · S · T	2 x 45°	Without	0.22
	AC Ammeter	RC310-1A20	AK2R1-A42	2	OFF · R · S · T	3 x 45°	With	0.22
	AC Ammeter	RC310-1A3	AK2R1-A33	3	R · S · T	2 x 45°	Without	0.25
	AC Ammeter	RC310-1A30	AK2R1-A43	3	OFF · R · S · T	3 x 45°	With	0.25

Note: * For standard type legend plate. Other types can be manufactured by request.

■ Ratings

Series	Rated thermal current (A)	Making and breaking capacity AC (inductive)			DC (inductive)		
		Voltage (V)	Make (A)	Break (A)	Voltage (V)	Make (A)	Break (A)
NS387	15	110	30	30	24	60	60
		220	30	30	110	15	15
		440	20	20	220	5	5
		550	20	20	440	2.5	2.5
RC310	10	110	37.5	7.5	24	37.5	7.5
		220	37.5	7.5	110	37.5	1.3
		440	37.5	2.5	220	37.5	0.45
		550	37.5	1.5	440	37.5	0.15

■ Dimensions, mm

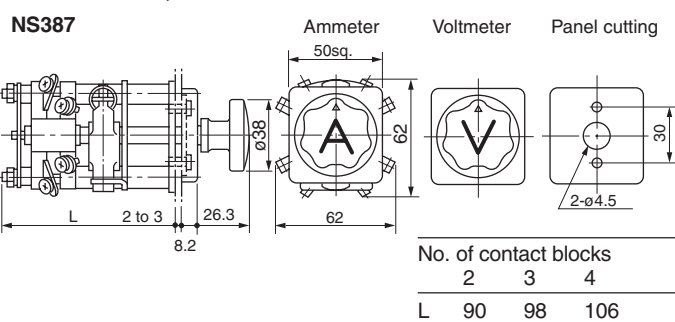

■ Handle color (standard)

NS387: Black
RC310: Black

■ Special spanner

Use this spanner for installation or replacement.

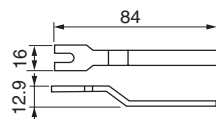

RC310

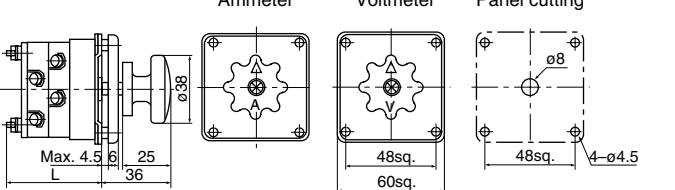

Note: Do not remove the wires connected.

■ **Wiring diagrams**

Voltmeter changeover switches

• **NS387 series**

NS387/4V

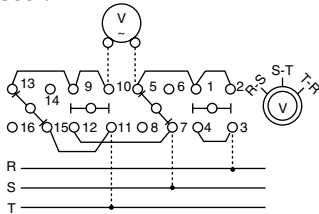

NS387/2V

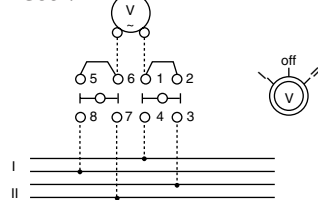

NS387/4V0

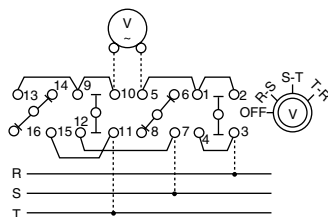

• **RC310 series**

RC310-1V

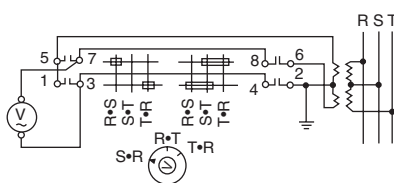

RC310-1V0

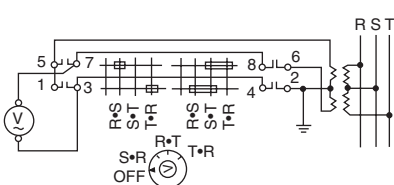

Ammeter changeover switches

• **NS387 series**

NS387/2M

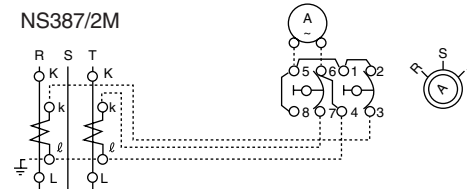

NS387/2M0

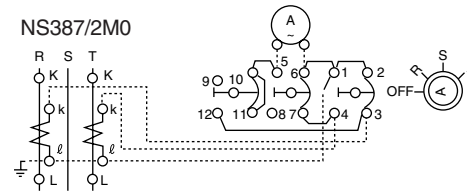

NS387/3M

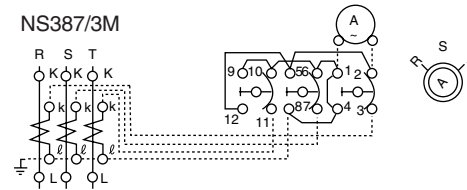

NS387/4M

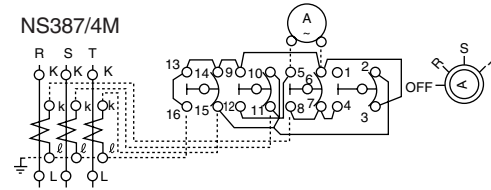

• **RC310 series**

RC310-1A2

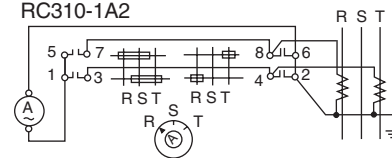

RC310-1A20

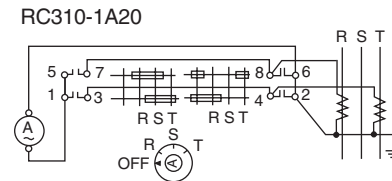

RC310-1A3

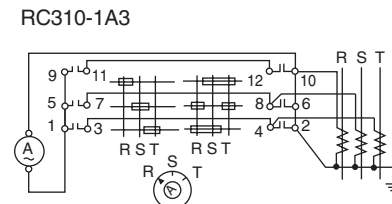

RC310-1A30

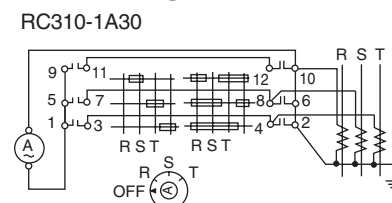

Panel Switches

NS387

Control switches

Panel switches for industrial control switchboards

■ Description

NS387 control switches are used on control panels or consoles to operate H.V. circuit breakers or disconnecting switches. These switches are small in size, dependable and take up little switchboard space. Since they have a large current capacity they can be applied to many types of control circuits.

The movable blade has both an excellent contact performance and a long service life. Switches can be supplied in center spring return for momentary action and maintained versions, with 2, 3 and 4 positions. They can be fitted with H, K or R-type standard FUJI handles. The H-type is used as an ON-OFF switch to control circuit breakers or as a disconnecting switch. The K-type is mainly for regulation use and the R-type is used for controlling the power source. In addition to the standard handles key-controlled handles are also available.

Please refer to page 04/225 of this catalog for typical contact arrangements of these panel switches. We are in a position to supply many other types of switches to meet your particular application needs.

■ Technical data

Insulation resistance: Over 25Ω at 500V DC
Dielectric strength: 2200V AC rms, 1 minute
Durability

Mechanical: 300,000 operations
Electrical: 100,000 operations at 220V AC 5A
Allowable ambient temperature: -5° to +40°C

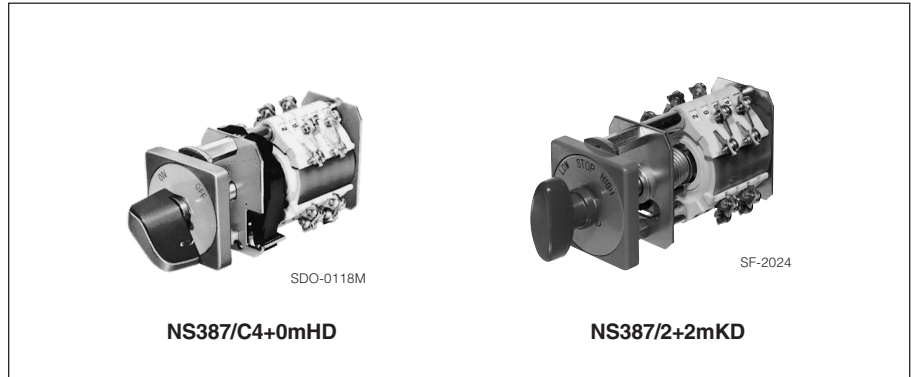
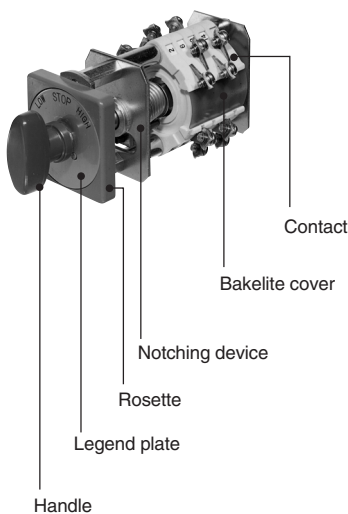

■ Ratings

Contacts	Rated thermal current (A)	Making and breaking capacity				AC (inductive) [VA]			
		DC (inductive) [W]				110V	220V	440V	550V
		24V	110V	220V	440V				
Standard contact	15	1440	1650	1100	1100	3300	6600	8800	11000
Residual contact	15	1440	1650	550	220	-	-	-	-
Non-break contact	15	720	825	550	132	-	-	-	-

■ Dimensions, mm

With H, I, R, K, KP, KQ, KX, KY type handle

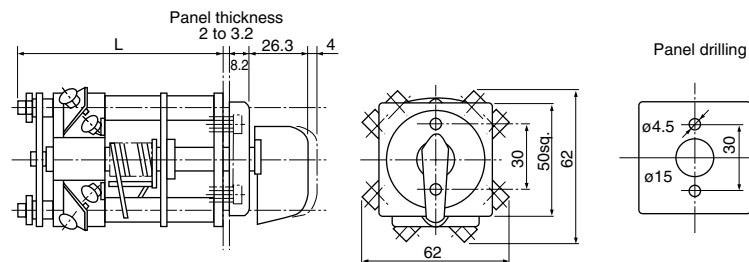

Type	No. of contact blocks									
	1	2	3	4	5	6	7	8	9	10
NS387/	82	90	98	106	114	123	131	139	147	155
NS387S/	82	90	98	106	114	123	131	139	147	155
NS387/C	82	90	98	106	114	139	147	155	163	171
NS387/A	82	90	98	106	114	123	131	139	147	155
NS387/D	82	90	98	106	114	123	131	139	147	155
Mass (kg)	0.4	0.43	0.47	0.5	0.54	0.57	0.61	0.64	0.68	0.71

■ Special spanner

Use this spanner for installation or replacement

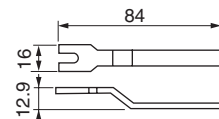

■ Ordering information

Specify the following (See page 04/223)

1. Type number
2. Letters or symbols to be printed on legend plate
3. Color of rosette (if you require other color but black standard color)
4. Color of handle
5. Options if required

■ Type number nomenclature

NS387 / D 1 + 1 + 1m + 1m S1 H1 B L2
 Basic type ① ② ③ ④ ⑤ ⑥ ⑦ ⑧

Construction
 Blank: Open type
 C: With transparent cover

Residual contact
 Blank: Without residual contact
 S: With residual contact
 Notes: • Only the spring return type can be manufactured. Refer to the following description for the operation of the contacts.
 • Two blocks are added to the end of the model contact blocks.

Operation
 C: Maintained, 2-position
 A: Maintained, 3-position
 F: Spring/ manual return, 3-position (Left to center)
 E: Spring/ manual return, 3-position (Right to center)
 Blank: Spring return, 3-position
 D: Maintained, 4-position

Contact arrangement

Handle locking device
 See page 04/224

Color of handle and rosette
 B: Black
 D: Dark green
 Note: The standard: Black (B).

Type of handle
 See page 04/224

With or without of micro switch
 Blank: Without
 S1: With a micro switch
 S2: With two micro switch
 Note: Specify the type of handle locking device when ordering a model equipped with a micro switch.

Note: Specify the embossed characters when ordering a model equipped with a legend plate.

04

Contact arrangement	Code	Contact position	Contact (varies depending on operation)						No. of combinations (varies depending on operation)			
			Blank	C	A	D	F	E	C	A, D	Blank	Blank (with residual contact)
①	0-10	Contacts at right angles to the operating handle (in parallel to the operating handle only in the case of the 4-position changeover type)							①+③+④ ≤ 10-block ③+④ ≤ 4-block	①+②+③ +④ ≤ 10-block ③+④ ≤ 6-block	①+②+③ +④ ≤ 10-block ③+④ ≤ 4-block	①+②+③+④ ≤ 8-block ③+④ ≤ 4-block
②	Blank, 1-10	The above contacts ① shifted clockwise by 45°		-								
③	0m-6m	Non-interrupting contacts at right angles to the operating handle (in parallel to the operating handle only in the case of the 4-position changeover type) Code "m" is added after the number of blocks.										
④	Blank, 1m-6m	The above contacts ③ shifted clockwise by 45° Code "m" is added after the number of blocks.										

Notes: • In each of the above contact forms, the symbol □ refers to the position of the operating handle.
 • If no contacts are required, leave ② and ④ blank and enter "0" for ① and ③.

• Operation

Operation	No. of positions	Handle position	Operation angle	Code
Maintained	2		90°	C
	3		45°	A
	4			D
Spring return	(3)			Blank
Spring / manual return	(3)			F
	(3)			E

• Contact

Standard contact



Non-break contact

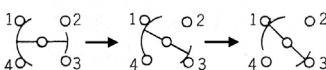

For clockwise rotation, terminals 1, 3, and 4 are conductive before the continuity of terminals 1 and 4 is interrupted. After that, only terminals 1 and 3 are conductive.

• Residual contact

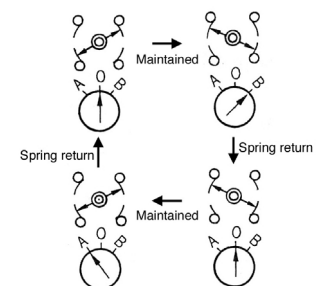

Residual contacts are used for the spring return type. The contacts will hold the state of A or B when the handle automatically returns to the center position after being turned in the A or B direction.

Panel Switches NS387 Controlswitches

■ Operating handle

• Combination of rosette and handle

Rosette	Handle	Type of handle (refer to 2. Shape of handle, table below)
For NS387	For NS387	Without micro switch: H, I, K KP1 – KP10 KQ1 – KQ10 KX1 – KX10 KY1 – KY10 R
		Key removable position
	For RC310	Without micro switch: P, S, D, W
		With micro switch: H, P, S, K, D, R, W

Notes: • With micro switch equipped, NS387 panel switch are provided with NS387-use rosette as standard, and with the handle for RS310-1 cam switch.
• The large handle (P, S, D, or W) for the RC310-1 is not compatible with any other handle.

• Shape of handle

For NS387	H type 	I type 	K type 	R type 	KP type 	KQ type 	KX type 	KY type
For RC310	H type 	R type 	W type 	S type 	P type 	K type 	D type 	

• Types of handle locking

Code	Center spring return type	Maintained type
Blank	In the case of the NS387, the handle can be turned after being pulled, and the handle then returns to the center position automatically when it is released. If the handle needs to be turned without being pulled, order a model with "no handle lock". The RC310 handle can be turned without being locked.	The handle can be turned without being locked.
L1	With a handle for the RC310. The handle can be turned after being pulled, and the handle then returns to the center position automatically when it is released.	The handle can be turned after being pulled, and the handle stops at each notch when it is released.
L2	The handle can be turned without being pulled, and will return to the center position automatically when it is released. The micro switch is activated while the handle is pulled in the center position, and the switch is reset when the handle is released. The handle, however, does not turn left or right when it is pulled.	The handle can be turned after being pulled, and when it is released in any notch position, the handle will stop at that notch position. Moreover, when the handle is pulled in any notch position, the micro switch will be activated, and both the micro switch and handle will be reset when the handle is released. However, the handle cannot be switched to any other notch while it is in the pulled condition.
L3	The handle can be turned without being pulled, and will return to the center position automatically when it is released. When the handle is pulled in the left position, the lock mechanism will activate and no other notch can be selected. In that case, the handle will automatically return to the center position when it is pressed in the shaft direction.	–
L4	The handle can be turned after being pulled. When it is released, the handle will automatically return to the center position in the pulled condition. The handle will return when it is pressed in the shaft direction.	–
L5	The handle can be turned without being pulled, and will return to the center position automatically when it is released. The micro switch will be activated when the handle is pulled in the center position, and the handle will return when the handle is pressed in the shaft direction.	–

Note: If a micro switch is equipped, it will be activated when the handle is pulled.

■ **Assembled typical switches**

Operation	Type(example)	Contact arrangement	Description
Center spring return	NS387/2 + 0mHD		<ul style="list-style-type: none"> The handle can be turned after being pulled, and will return to the center position automatically when it is released.
	NS387/2 + 2 + 0mHB		<ul style="list-style-type: none"> The handle can be turned after being pulled, and will return to the center position automatically when it is released.
	NS387/1 + 1mHB		<ul style="list-style-type: none"> The handle can be turned after being pulled, and will return to the center position automatically when it is released.
	NS387/2 + 0mS1B		<ul style="list-style-type: none"> RC310-1 handle, equipped with a rosette. Add L1 for the pull-and-turn type.
	NS387/1 + 0mS1HDL2		<ul style="list-style-type: none"> Provided with a micro switch, RC310-1 handle, and a rosette for the NS387. The handle can be turned without being pulled, and will return to the center position automatically when it is released. The micro switch will be activated while the handle is pulled in the center position.
	NS387/5 + 0mSBL3		<ul style="list-style-type: none"> RC310-1 handle, equipped with the NS387 rosette. When the handle is pulled in the left position, it will be locked, and the handle will automatically return to the center position when it is pressed in the shaft direction.
	NS387/1 + 0mS1H1BL4		<ul style="list-style-type: none"> Equipped with a micro switch, RC310-1 handle, and a rosette for the NS387. The handle can be turned after being pulled, and will return to the center position automatically when it is released, but the handle remains in the pulled condition. The handle will be reset when it is pressed. The micro switch will be activated while the handle is pulled.
Center spring return with residual contact and with locking device	NS387S/2 + 0mHB		—
	NS387S/2 + 1+ 0mHB		—
	NS387S/2 + 2mHB		—
Maintained 2-position	NS387/C3 + 1mKB		—
	NS387/C6 + 0mW1D		<ul style="list-style-type: none"> RC310-1 cam switch handle, equipped with a rosette.
Maintained 3-position	NS387/A6 + 0mRB		—
	NS387/A2 + 0mH1B		<ul style="list-style-type: none"> RC310-1 cam switch handle, equipped with a rosette.
	NS387/A3 + 3 + 0mS1KDL2		<ul style="list-style-type: none"> RC310-1 cam switch handle, equipped with the NS387 rosette. The handle can be turned left or right without being pulled. The micro switch will be activated while the handle is pulled.
Maintained 4-position	NS387/D4 + 1 + 1mRB		—
	NS387/D4 + 0mS1S1BL1		<ul style="list-style-type: none"> RC310-1 cam switch handle, equipped with a rosette. The handle can be turned when it is pulled, and when it is released in a notch position, the handle will be locked in the notch. The micro switch will be activated while the handle is pulled.
	NS387/D2 + 2 + 0mS2KDL2		<ul style="list-style-type: none"> RC310-1 cam switch handle, equipped with the NS387 rosette. The handle can be turned left or right without being pulled. The micro switch will be activated while the handle is pulled.

For other than above, contact FUJI.