

FUJI AC SERVO SYSTEM  
**FALDIC- $\alpha$**   
Series





FUJI AC SERVO SYSTEM  
**FALDIC- $\alpha$**   
**Series**

**Model line up** .....  
**SERVOMOTOR**

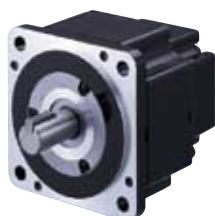

**Cubic type**

Having a drastically shorter depth, the motor does not remarkably protrude to the rear of the machine when mounted.



**Slim type**

A small flange allows the motor to fit into a small area.

**CONTENTS**

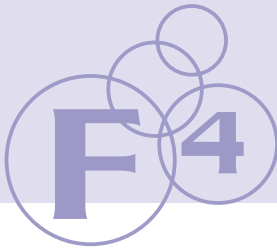

**Fuji's compact servo system, packed with advanced control technologies, meets new industry standards.**

The new FALDIC- series has come onstage with enhanced fundamental functions and a variety of other useful functions such as an easy-to-operate PC loader and real-time tuning of the mechanical systems. These help shorten your setup time as well as improve your machine's performance.

**Features of the FALDIC- $\alpha$**

**F**ine

Frequency response at 600Hz and a settling time of 1 ms provide amazing control capability. The servo motor incorporates a real-time tuning function to automatically adjust the gain even when the moment of load inertia fluctuates.

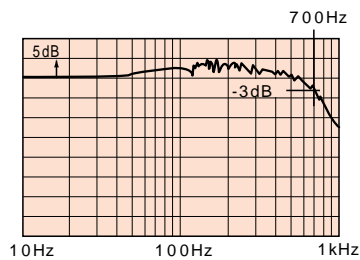

**F**riendly

From the selection of a suitable servo motor capacity, to test operation of the motor, maintenance and inspection, as well as diagnosis of alarms, the personal computer loader helps navigate you through all processes. The servo amplifiers radiate less heat horizontally and can be installed side by side with very little or no clearance between them. (If they are completely fitted to each other, however, the cyclic duty factor will be reduced to 80%ED.)



**F**lexible

The servo motor, equipped with a 16-bit serial encoder which can be used for both incremental and absolute position feedback systems, requires less wiring and keeps the motor wow at low level.

The encoder connects with four cables: two for power and two for signals. (To construct an absolute position feedback system, however, two other lines are required to connect with the battery.)

The motor can be operated in combination with the encoder without changing the encoder settings, even though such combination is not specified as the standard combination.

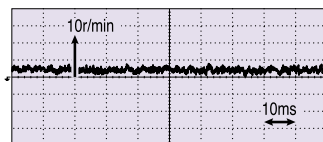

**F**acility

The servomotors are so compactly designed that they can be mounted even in a small area. Servo amplifiers are available in three types; velocity control, linear positioning, and rotation angle index type. Choose one according to your needs. The servomotors meet foreign standards. (The standard model meets CE marking and is planning to achieve UL/cUL standards.)



**SERVO AMPLIFIER**



**V type (Velocity)**

**Servo amplifier for motor velocity control using a pulse train or speed command**

The amplifier rotates the motor according to the specified pulse train command or analog speed command issued from the host control unit.



**L type (Linear motion)**

**Servo amplifier with linear positioning function**

You can construct a linear positioning system using such machine components as a ball screw or rack & pinion.



**R type (Rotation)**

**Servo amplifier with rotation angle indexing function**

You can construct a rotation angle index system such as that for an ATC, tool magazine, or transfer unit.

## SERVOMOTOR

### 16-bit serial encoder

The servomotor is standard-equipped with a 4Mbps serial encoder that can generate 65536 pulses/revolution. These components are connected with only four wires.

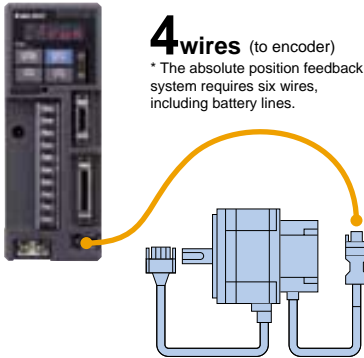

### Specifications common to 50W to 5kW

There are two types of motors: a cubic type (ranging from 100W to 2kW) with a short depth, and a slim type with a small flange. Using both types, you can select a motor with a brake or a gear head.

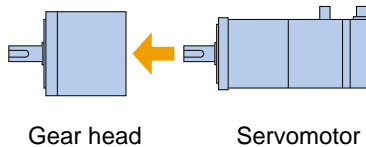

### High-speed response and low motor wow

The power rate of the slim type is 65kW/s. The motor returns to the rated speed by accelerating or decelerating in approximately 2ms. (0.4kW servomotor, no load at shaft end) A 16-bit serial encoder keeps the motor wow at a low level by generating 65536 pulses.

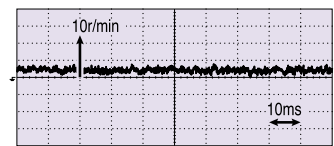

## SERVO AMPLIFIER

### Servo amplifier can be used for incremental and absolute position feedback

An absolute position feedback system can be constructed by connecting a battery to the servo amplifier.

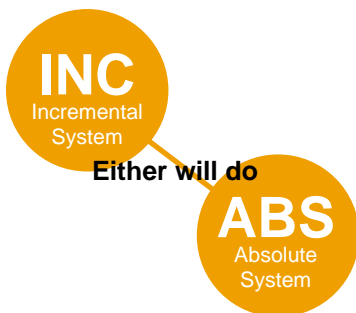

### Automatic detection of servomotor type

The amplifier detects the motor type (cubic or slim) and the motor capacity. Therefore, you can operate the motor simply by supplying power to the amplifier.

- The servomotor and the servo amplifier are ranked at the same capacity level.
- The servomotor is ranked higher or lower than the servo amplifier by one capacity level (3-phase 200V series).

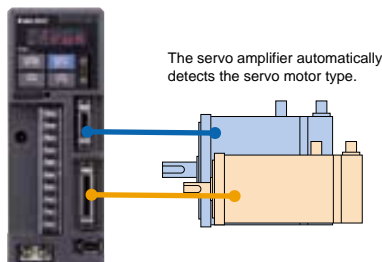

### High-speed response

The amplifier detects changes in the status of the ON/OFF control signal in 1ms.

The amplifier quickly responds to the signal change sent from the host control unit.

The amplifier achieves a frequency response of 600Hz by combining with a low inertia motor.

Personal computer loader

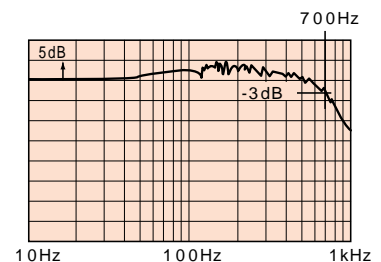

## Personal computer loader

### Monitor

When you connect the personal computer loader and the servo amplifier, you can continuously monitor the servo amplifier operating condition. Both real-time trace and historical trace are available as a monitoring method.





## Application Examples

FALDIC- series are used in the following applications.

### PC board inspecting machine

This machine moves the printed circuit board sequentially so that a camera can properly capture the portion to be inspected. The board moves in the registration order of position data.

**Control method:**  
synchronized operation, linear positioning

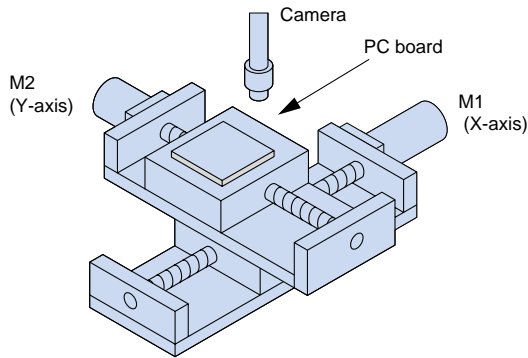

### Horizontal pillow-type packaging machine

This machine packages a piece of bread or the like one by one. The machine pulls and rolls a sheet of film like a pillow, packages a product in it, and then seals and cuts the film. The servo system determines the sealer and conveyor positions in synchronization with the film pulling motion.

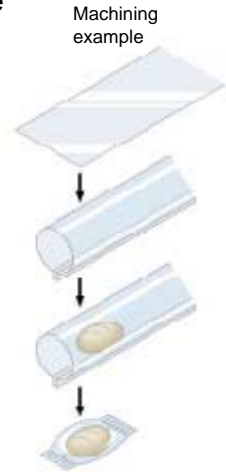

**Control method:**  
synchronized operation

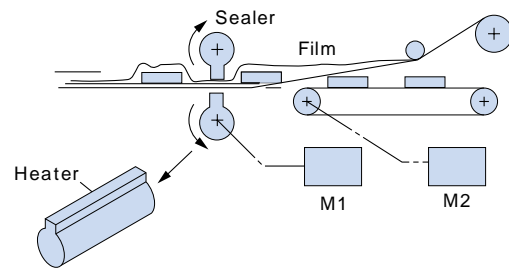

### Staggered holes drilling machine

This machine drills holes in staggered positions on a pipe. The servo system controls the vertical travel and rotation speed of a drill and the front-back movement and rotation of a pipe.

Machining example



**Control method:**  
linear and rotary positioning

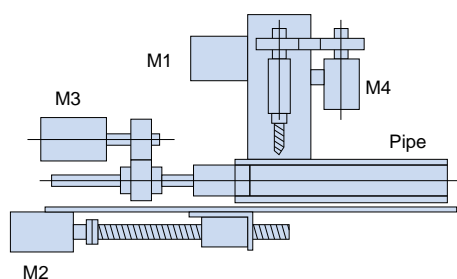

### ATC (automatic tool changer)

This unit automatically changes the tools on the machine tool. When a tool number is given, the servo system indexes the relevant tool to the tool change position. The system can index the tool by rotating the turret either in one direction or in whichever direction closer to the tool change position. On completion of indexing, the ATC mechanically locks the turret.

**Control method:**  
rotation angle indexing

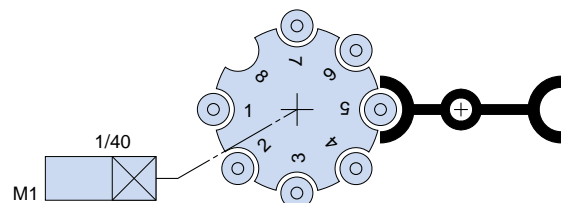

# Description of Functions

## Functions of the Personal Computer Loader and Servo Amplifier

Loader functions		Specifications
Monitor 1	Historical trace	Sampling time: 1, 2, 5, 10, 20, 50, 100, and 200ms Min. sampling time: 1ms. Data capacity: 100 points
	Real-time trace	Sampling time: 50, 100, and 200ms Min. sampling time: 50ms. Data capacity: 25000 points
	Saving monitored waveforms	Monitored data can be saved in a file or printed. * Saving in a waveform format such as CSV is possible.
Monitor 2	I/O monitor	Graphically displays the ON/OFF status of control input/output signals.
	I/O link monitor	Graphically displays the ON/OFF status of signals in links such as T-link or SX bus.
	System monitor	Displays the servo amplifier and servomotor types and their major functions.
Test operation		Manual feed, zero return, pulse train feed, etc.
Parameter editing	List edit	Allows you to edit standard and system parameters in numerical order.
	Editing for each function	Allows you to edit standard and system parameters that are classified by function.
	Comparison	Compares the data being edited with servo amplifier data and file data. (Possible to comparatively display the results.)
	Initialization	Initializes servo amplifier parameters and the data being edited.
	File information	Displays the parameter information being edited.
	Data transfer	Transfers all data or only changed data.
Editing positioning data		Editing positioning data Editing position, feed rate, timer, M code, and status data
Diagnosis		Alarm type (on-line data display of alarm cause, remedy, and time of alarm detection) No alarm (on-line data display of the cause of such trouble as non-operation or vibration, and the remedy)

Servo amplifier functions	Specifications
Sampling data	Analog data and control input/output signals (ON/OFF)
Data capacity	100 points
Storage of memory	Cyclic
Sampling interval	1, 2, 5, 10, 20, 50, 100, and 200ms (set on the loader)
Start/stop	Trigger conditions (set on the loader)



## Description of Functions

<p><b>Soft start</b></p> <p>The motor rotates and stops smoothly in the preset acceleration/deceleration time. External signals can be used to change the start/stop conditions.</p> <p><b>L R V</b></p>	<p><b>Switching the direction of rotation</b></p> <p>The motor rotation direction can be switched between forward and reverse, without the need to change the wiring.</p> <p><b>L R V</b></p>	<p><b>Pulse offset function</b></p> <p>The set value becomes the actual travel of a mechanism.</p> <p><b>L</b></p>
<p><b>Current limit function</b></p> <p>The output current (torque) can be limited by an external signal. This function is used to prevent damage to the machine.</p> <p><b>L R V</b></p>	<p><b>Programmable terminal</b></p> <p>Required functions can be assigned to the input/output terminals. You can select the signals required for your machine's operation.</p> <p><b>L R V</b></p>	<p><b>One-point stop</b></p> <p>The motor can stop the rotary axis at a specified position. In addition, it can index the rotary axis to a maximum 30,000 divisions.</p> <p><b>R</b></p>
<p><b>Brake timing</b></p> <p>The motor incorporates brake excitation and release timers.</p> <p><b>L R V</b></p>	<p><b>Alarm history</b></p> <p>The amplifier retains records of the last nine alarms. Refer to this for easy maintenance and inspection.</p> <p><b>L R V</b></p>	<p><b>Positioning by interruption</b></p> <p>You can stop the motor after sending a fixed amount of pulses with an external signal.</p> <p><b>L V</b></p>

## System Configuration

### Applicable to various host interfaces

The servo amplifier can be directly connected to various networks. The MICREX-SX system can be loaded with the pulse train output module and various compound modules. The SX system is also equipped with a function board for simple positioning; that for 4-axis interpolation, and that for cutting-off.

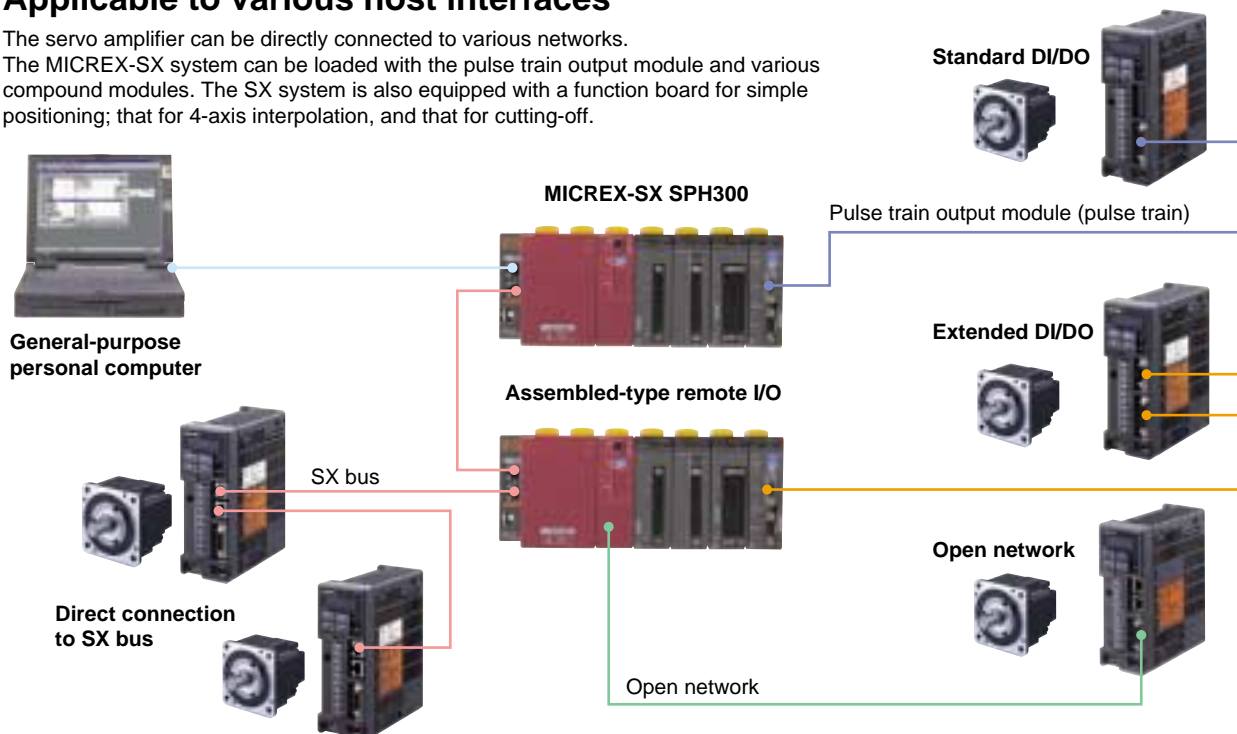

## SERVO MOTOR 200V series

[Cubic type ] 0.1~2kW

### Standard type

Motor type		GYC101DC1-SA	GYC201DC1-SA	GYC401DC1-SA	GYC751DC1-SA
Rated output	[kW]	0.1	0.2	0.4	0.75
Rated torque	[N·m]	0.318	0.637	1.27	2.39
Rated speed	[r/min]	3000			
Max. speed	[r/min]	5000			
Max. torque	[Nm]	0.955/1.43	1.91/2.87	3.82/5.73	7.17/10.7
Moment of inertia	[kg·m <sup>2</sup> ]	0.00538×10 <sup>-3</sup>	0.0216×10 <sup>-3</sup>	0.0412×10 <sup>-3</sup>	0.121×10 <sup>-3</sup>
Rated Current	[A]	1.0	1.5	2.6	4.8
Max. Current	[A]	3.0/4.5	4.5/6.8	7.8/11.8	14.4/21.6
Winding insulation class		B			
Operation duty type		Continuous			
Degree of enclosure protection		Totally enclosed, self cooled (IP55)			
Terminals (motor)		With 0.3-m flexible leads and connectors			
Terminals (encoder)		With 0.3-m flexible leads and connectors			
Overheat protection		Not provided (Servo amplifier detects temperature.)			
Mounting method		By securing motor flange IMB5 (L51), IMV1 (L52), IMV3 (L53)			
Shaft extension		Straight shaft with a key			
Paint color		Munsell N1.5 (flat paint)			
Encoder		16-bit serial encoder (Possible to construct ABS system by connecting a battery to the servo amplifier.)			
Vibration level		V5 or under			
Installation place, altitude		For indoor use, 1000m or below			
Ambient temperature, humidity		-10 to +40°C, 90% RH max. (without condensation)			
Vibration resistance	[m/s <sup>2</sup> ]	49			
Mass	[kg]	0.75	1.3	1.9	3.5

Note: Motors with a capacity of 3.0 kW or over are under development.

### Motor with a brake

Motor type		GYC101DC1-SA-B	GYC201DC1-SA-B	GYC401DC1-SA-B	GYC751DC1-SA-B
Rated output	[kW]	0.1	0.2	0.4	0.75
Rated torque	[N·m]	0.318	0.637	1.27	2.39
Braking torque	[N·m]	0.318	1.27	1.27	2.39
Rated DC voltage	[V]	24V DC			
Attraction time	[ms]	60	80	80	50
Release time	[ms]	40	40	40	80
Braking power	[W]	6.5	9	9	8.5
Mass	[kg]	1	1.9	2.6	4.3

Note: The brake is used to hold the rotor.

### Gear head (gear ratio 1/9)

Gear head type		GYN101CAG-G09	GYN201CAG-G09	GYN401CAG-G09	GYN751CAG-G09
Actual speed reduction ratio		1/9			
Rated speed	[r/min]	333.3			
Max. speed	[r/min]	555.5			
Rated torque	[N·m]	2.45	4.9	9.8	18.1
Breakdown (max.) torque	[N·m]	7.35	14.7	29.4	54.4
Direction of motor rotation*		CCW			
Backlash	[min]	Max. 40	Max. 30		
Lubrication		Long-life grease (Sumiplex MP No.2)			
Mass	[kg]	0.72	2.1	2.1	3.8

\*: When the motor shaft rotates forward, the gear output shaft rotates in CCW (counter-clockwise) direction.

### Gear head (gear ratio 1/25, 1/15)

Gear head type		GYN101CAG-G25	GYN201CAG-G25	GYN401CAG-G25	GYN751CAG-G25
Actual speed reduction ratio		1/25			
Rated speed	[r/min]	120			
Max. speed	[r/min]	200			
Rated torque	[N·m]	6.37	12.7	25.5	48
Breakdown (max.) torque	[N·m]	19.1	38.2	76.4	144
Direction of motor rotation*		CCW			
Backlash	[min]	Max. 40 min.	Max. 30 min.		
Lubrication		Long-life grease (Sumiplex MP No.2)			
Mass	[kg]	0.72	2.1	2.1	3.8

\*: When the motor shaft rotates forward, the gear output shaft rotates in CCW (counter-clockwise) direction.

Motor type	GYC102DC1-SA	GYC152DC1-SA	GYC202DC1-SA
Rated output [kW]	1.0	1.5	2.0
Rated torque [N·m]	3.18	4.78	6.37
Rated speed [r/min]	3000		
Max. speed [r/min]	5000		
Max. torque [N·m]	9.55/12.7	14.3/19.1	19.1
Moment of inertia [kg·m <sup>2</sup> ]	0.326×10 <sup>-3</sup>	0.451×10 <sup>-3</sup>	0.575×10 <sup>-3</sup>
Rated Current [A]	6.7	9.6	12.6
Max. Current [A]	20.1/26.8	28.8/38.4	37.8
Winding insulation class	F		
Operation duty type	Continuous		
Degree of enclosure protection	Totally enclosed, self cooled (IP55)		
Terminals (motor)	With cannon connectors		
Terminals (encoder)	With cannon connectors		
Overheat protection	Not provided (Servo amplifier detects temperature.)		
Mounting method	By securing motor flange IMB5 (L51), IMV1 (L52), IMV3 (L53)		
Shaft extension	Straight shaft with a key		
Paint color	Munsell N1.5 (flat paint)		
Encoder	16-bit serial encoder (Possible to construct ABS system by connecting a battery to the servo amplifier.)		
Vibration level	Max. V10 (3000 r/min or less), Max. V15 (3001 to 5000 r/min)		
Installation place, altitude	For indoor use, 1000m or below		
Ambient temperature, humidity	-10 to +40°C, 90% RH max. (without condensation)		
Vibration resistance [m/s <sup>2</sup> ]	24.5m/s <sup>2</sup>		
Mass [kg]	5.7	7.0	8.2

Motor type	GYC102DC1-SA-B	GYC152DC1-SA-B	GYC202DC1-SA-B
Rated output [kW]	1.0	1.5	2.0
Rated torque [N·m]	3.18	4.78	6.37
Braking torque [N·m]	17		
Rated DC voltage [V]	24V DC		
Attraction time [ms]	120	120	120
Release time [ms]	30	30	30
Braking power [W]	12	12	12
Mass [kg]	8.0	9.8	11.0

Gear head type	GYN102CAG-G09	GYN152CAG-G09	GYN202CAG-G09
Actual speed reduction ratio	1/9		
Rated speed [r/min]	333.3		
Max. speed [r/min]	555.5		
Rated torque [N·m]	25.4	38.2	50.9
Breakdown (max.) torque [N·m]	76.4	114	152
Direction of motor rotation*	CCW		
Backlash [min]	Max. 30		
Lubrication	Long-life grease (Sumiplex MP No.2)		
Mass [kg]	7.8	7.8	12.2

\*: When the motor shaft rotates forward, the gear output shaft rotates in CCW (counter-clockwise) direction.

Gear head type	GYN102CAG-G15	GYN152CAG-G15	GYN202CAG-G15
Actual speed reduction ratio	1/15		
Rated speed [r/min]	200		
Max. speed [r/min]	333.3		
Rated torque [N·m]	39.2	57.8	77.4
Breakdown (max.) torque [N·m]	117	173	232
Direction of motor rotation*	CCW		
Backlash [min]	Max. 30		
Lubrication	Long-life grease (Sumiplex MP No.2)		
Mass [kg]	7.8	7.8	12.2

\*: When the motor shaft rotates forward, the gear output shaft rotates in CCW (counter-clockwise) direction.

## SERVO MOTOR 200V series

[Slim Type type] 0.05~5kW

### ■Standard type

Motor type	GYS500DC1-S8B	GYS101DC1-SB	GYS201DC1-SA	GYS401DC1-SA	GYS751DC1-SA
Rated output [kW]	0.05	0.1	0.2	0.4	0.75
Rated torque [N·m]	0.159	0.318	0.637	1.27	2.39
Rated speed [r/min]	3000				
Max. speed [r/min]	5000				
Max. torque [Nm]	0.478	0.955	1.91/2.87	3.82/5.73	7.17/10.7
Moment of inertia [kg·m <sup>2</sup> ]	0.00341×10 <sup>-3</sup>	0.00517×10 <sup>-3</sup>	0.0137×10 <sup>-3</sup>	0.0249×10 <sup>-3</sup>	0.0861×10 <sup>-3</sup>
Rated Current [A]	0.85	0.85	1.5	2.6	4.8
Max. Current [A]	2.55	2.55	4.5/6.8	7.8/11.8	14.4/21.6
Winding insulation class	B				
Operation duty type	Continuous				
Degree of enclosure protection	Totally enclosed, self cooled (IP55)				
Terminals (motor)	With 0.3-m flexible leads and connectors				
Terminals (encoder)	With 0.3-m flexible leads and connectors				
Overheat protection	Not provided (Servo amplifier detects temperature.)				
Mounting method	By securing motor flange IMB5 (L51), IMV1 (L52), IMV3 (L53)				
Shaft extension	Straight shaft without key		Straight shaft with a key		
Paint color	Munsell N1.5 (flat paint)				
Encoder	16-bit serial encoder (Possible to construct ABS system by connecting a battery to the servo amplifier.)				
Vibration level	V5 or under				
Installation place, altitude	For indoor use, 1000m or below				
Ambient temperature, humidity	-10 to +40°C, 90% RH max. (without condensation)				
Vibration resistance	49m/s <sup>2</sup>				
Mass [kg]	0.45	0.55	1.2	1.8	3.4

Notes: 1) Contact your nearest sales office for 0.03kW motor.  
2) The 0.05kW motor is shared with 100V series.

3) Select the shaft with a key only when using 50W or 100W motor in combination with a gear head.

### ■Motor with a brake

Motor type	GYS500DC1-S8B-B	GYS101DC1-SB-B	GYS201DC1-SA-B	GYS401DC1-SA-B	GYS751DC1-SA-B
Rated output [kW]	0.05	0.1	0.2	0.4	0.75
Rated torque [N·m]	0.159	0.318	0.637	1.27	2.39
Braking torque [N·m]	0.3		1.27	1.27	2.45
Rated DC voltage [V]	24V DC				
Attraction time [ms]	35		40	40	60
Release time [ms]	10		20	20	25
Braking power [W]	6.1		7.3	7.3	8.5
Mass [kg]	0.62	0.72	1.7	2.3	4.2

Notes: 1) The 0.05 kW motor is shared with 100V series. 2) The brake is used to hold the rotor.

### ■Gear head (gear ratio 1/9)

Gear head type	GYN500SAG-G09	GYN101SAG-G09	GRN.20SAG-G09	GRN.40SAG-G09	GRN751SAG-G09
Actual speed reduction ratio	1/9				
Rated speed [r/min]	333.3				
Max. speed [r/min]	555.5				
Rated torque [N·m]	1.23	2.45	4.9	9.8	18.1
Breakdown (max.) torque [N·m]	3.68	7.36	14.7	29.4	54.3
Direction of motor rotation*	CCW				
Backlash [min]	Max. 40		Max. 30		
Lubrication	Long-life grease (Sumiplex MP No.2)				
Mass [kg]	0.7	0.7	2.1	2.1	3.8

\*: When the motor shaft rotates forward, the gear output shaft rotates in CCW (counter-clockwise) direction.

### ■Gear head (gear ratio 1/25, 1/15)

Gear head type	GYN500SAG-G25	GYN101SAG-G25	GRN.20SAG-G25	GRN.40SAG-G25	GYN751SAG-G25
Actual speed reduction ratio	1/25				
Rated speed [r/min]	120				
Max. speed [r/min]	200				
Rated torque [N·m]	3.19	6.38	12.7	25.5	48
Breakdown (max.) torque [N·m]	9.56	19.1	38.2	76.4	144
Rotating direction of output shaft*	CCW				
Backlash [min]	Max. 40		Max. 30		
Lubrication	Long-life grease (Sumiplex MP No.2)				
Mass [kg]	0.7	0.7	2.1	2.1	3.8

\*: When the motor shaft rotates forward, the gear output shaft rotates in CCW (counter-clockwise) direction.

Motor type	GYS102DC1-SA	GYS152DC1-SA	GYS202DC1-SA	GYS302DC1-SA	GYS402DC1-SA	GYS502DC1-SA
Rated output [kW]	1.0	1.5	2.0	3.0	4.0	5.0
Rated torque [N·m]	3.18	4.78	6.37	9.55	12.7	15.9
Rated speed [r/min]	3000					
Max. speed [r/min]	5000					
Max. torque [N·m]	9.55/12.7	14.3/19.1	19.1	28.7	38.2	47.8
Moment of inertia [kg·m <sup>2</sup> ]	0.174×10 <sup>-3</sup>	0.238×10 <sup>-3</sup>	0.302×10 <sup>-3</sup>	0.873×10 <sup>-3</sup>	1.12×10 <sup>-3</sup>	1.37×10 <sup>-3</sup>
Rated Current [A]	7.1	9.6	12.6	18.5	24.5	30
Max. Current [A]	21.3/28.4	28.8/38.4	37.8	55.5	73.5	90
Winding insulation class	F					
Operation duty type	Continuous					
Degree of enclosure protection	Totally enclosed, self cooled (IP55)					
Terminals (motor)	With cannon connectors					
Terminals (encoder)	With cannon connectors					
Overheat protection	Not provided (Servo amplifier detects temperature.)					
Mounting method	By securing motor flange IMB5 (L51), IMV1 (L52), IMV3 (L53)					
Shaft extension	Straight shaft with a key					
Paint color	Munsell N1.5 (flat paint)					
Encoder	16-bit serial encoder (Possible to construct ABS system by connecting a battery to the servo amplifier.)					
Vibration level	Max. V10 (3000 r/min or less), Max. V15 (3001 to 5000 r/min)					
Installation place, altitude	For indoor use, 1000m or below					
Ambient temperature, humidity	-10 to +40°C, 90% RH max. (without condensation)					
Vibration resistance	24.5m/s <sup>2</sup>					
Mass [kg]	4.4	5.2	6.3	11.0	13.5	16.0

Motor type	GYS102DC1-SA-B	GYS152DC1-SA-B	GYS202DC1-SA-B	GYS302DC1-SA-B	GYS402DC1-SA-B	GYS502DC1-SA-B
Rated output [kW]	1.0	1.5	2.0	3.0	4.0	5.0
Rated torque [N·m]	3.18	4.78	6.37	9.55	12.7	15.9
Braking torque [N·m]	6.86	6.86	17	17	17	17
Rated DC voltage [V]	24V DC					
Attraction time [ms]	60	60	120	120	120	120
Release time [ms]	10	10	30	30	30	30
Braking power [W]	17	17	12	12	12	12
Mass [kg]	5.9	6.8	7.9	13.0	15.5	18.0

Gear head type	GYN102SAG-G09	GYN152SAG-G09	GYN202SAG-G09	GYN302SAG-G09	GYN402SAG-G09	GYN502SAG-G09
Actual speed reduction ratio	1/9					
Rated speed [r/min]	333.3					
Max. speed [r/min]	555.5					
Rated torque [N·m]	25.4	38.2	50.9			
Breakdown (max.) torque [N·m]	74.4	114	152			
Direction of motor rotation*	CCW					
Backlash [min]	Max. 30					
Lubrication	Long-life grease (Sumiplex MP No.2)					
Mass [kg]	7.8	7.8	7.8			

Under planning

\*: When the motor shaft rotates forward, the gear output shaft rotates in CCW (counter-clockwise) direction.

Gear head type	GYN102SAG-G15	GYN152SAG-G15	GYN202SAG-G15	GYN302SAG-G15	GYN402SAG-G15	GYN502SAG-G15
Actual speed reduction ratio	1/15					
Rated speed [r/min]	200					
Max. speed [r/min]	333.3					
Rated torque [N·m]	39.2	57.8	77.4			
Breakdown (max.) torque [N·m]	117	173	232			
Rotating direction of output shaft*	CCW					
Backlash [min]	Max. 30					
Lubrication	Long-life grease (Sumiplex MP No.2)					
Mass [kg]	7.8	7.8	7.8			

Under planning

\*: When the motor shaft rotates forward, the gear output shaft rotates in CCW (counter-clockwise) direction.

## SERVO MOTOR 100V series

[Slim Type ] 0.05~0.2kW

### ■Standard type

Motor type		GYS500DC1-S8B	GYS101DC1-S6B	GYS201DC1-S6B
Rated output	[kW]	0.05	0.1	0.2
Rated torque	[N·m]	0.159	0.318	0.637
Rated speed	[r/min]	3000		
Max. speed	[r/min]	5000		
Max. torque	[N·m]	0.478	0.955	1.91
Moment of inertia	[kg·m <sup>2</sup> ]	0.00341×10 <sup>-3</sup>	0.00517×10 <sup>-3</sup>	0.0137×10 <sup>-3</sup>
Rated Current	[A]	0.85	1.5	2.7
Max. Current	[A]	2.55	4.5	8.1
Winding insulation class		B		
Operation duty type		Continuous		
Degree of enclosure protection		Totally enclosed, self cooled (IP55)		
Terminals (motor)		With 0.3-m flexible leads and connectors		
Terminals (encoder)		With 0.3-m flexible leads and connectors		
Overheat protection		Not provided (Servo amplifier detects temperature.)		
Mounting method		By securing motor flange IMB5 (L51), IMV1 (L52), IMV3 (L53)		
Shaft extension		Straight shaft without key		
Paint color		Munsell N1.5 (flat paint)		
Encoder		16-bit serial encoder (Possible to construct ABS system by connecting a battery to the servo amplifier.)		
Vibration level		V5 or under		
Installation place, altitude		For indoor use, 1000m or below		
Ambient temperature, humidity		-10 to +40°C, 90% RH max. (without condensation)		
Vibration resistance		49m/s <sup>2</sup>		
Mass	[kg]	0.45	0.55	1.2

Note: The 0.05 kW motor is shared with 200V series

### ■Motor with a brake

Motor type		GYS500DC1-S8B-B	GYS101DC1-S6B-B	GYS201DC1-S6B-B
Rated output	[kW]	0.05	0.1	0.2
Rated torque	[N·m]	0.159	0.318	0.637
Braking torque	[N·m]	0.3	0.3	1.27
Rated DC voltage	[V]	24V DC		
Attraction time	[ms]	35	35	40
Release time	[ms]	10	10	20
Braking power	[W]	6.1	6.1	7.3
Mass	[kg]	0.62	0.72	1.7

Note: The 0.05 kW motor is shared with 200V series.

## SERVO AMPLIFIER (3-phase 200V Series)

### Basic type

Amplifier type	RYS500S3-□□S	RYS101S3-□□S	RYS201S3-□□S	RYS401S3-□□S	RYS751S3-□□S
Applicable motor output [kW]	0.05	0.1	0.2	0.4	0.75
Input power	Phase	3-phase for motor power, single-phase for control power			
	Voltage	200/200-220-230V, +10 to -15%			
	Frequency	50/60Hz			
Control system	Sinusoidal PWM current control (full digital)				
Carrier frequency [kHz]	10				
Feedback	16-bit serial encoder (resolution/revolution 16-bit, multi-revolution 16-bit)				
Speed variation	±1 [r/min] max.: load deviation 0 to 100%				
	±1 [r/min] max.: power fluctuation -10 to +10%				
	±2% max.: temperature variation 25°C±10°C at rated speed (by analog voltage input)				
Speed control accuracy	1:5000 (at rated load)				
Frequency response	600Hz [Moment of load inertia converted into motor shaft (JL)= Moment of motor inertia (JM): 100% load]				
Max. moment of load inertia	100 times of the motor rotor inertia (velocity control type)				
Overload capability	300% for 3 sec		300% for 3 sec, 450% for 1.5 sec		
Additional functions	Braking	Regenerative braking, dynamic braking with external braking resistor			
	Protection	overcurrent (OC), overspeed (OS), low voltage (Lv), high voltage (Hv), encoder trouble (Et), control power trouble (Ct), data or memory error (dE), combination error (CE), regenerative transistor overheat (rH2), encoder communication error (EC), control signal error (CtE), motor overload (OL), regenerative resistor overheat (rH), excessive deviation (OF), amplifier overheat (AH), encoder overheat (EH), absolute data lost (AL), absolute data overflow (AF)			
	Display, setting	CHARGE lamp (red), 5-digit 7-segment LED, and 4 operation keys			
Working conditions	Installation place	For indoor use at max altitude of 1000 m. The installation place shall be free from dust, corrosive gas, or direct sunlight. To meet the European standard: Pollution degree = 2, Overvoltage category =			
	Temp., humidity	-10 to +55°C, 10 to 90% RH (without condensation)			
	Vibration, shock	4.9m/s <sup>2</sup> , 19.6m/s <sup>2</sup>			
Others	DC reactor terminals (P1, P+) for suppressing harmonics The amplifier complies with UL508c (UL/cUL) and EN50178 (European standard).				
Mass [kg]	0.9			1.2	1.5

Amplifier type	RYS102S3-□□S	RYS152S3-□□S	RYS202S3-□□S	RYS302S3-□□S	RYS402S3-□□S	RYS502S3-□□S
Applicable motor output [kW]	1.0	1.5	2.0	3.0	4.0	5.0
Input	Phase	3-phase for motor power, single-phase for control power				
	Voltage	200/200-220-230V, +10 to -15%				
	Frequency	50/60Hz				
Control system	Sinusoidal PWM current control (full digital)					
Carrier frequency [kHz]	10	5				
Feedback	16-bit serial encoder (resolution/revolution 16-bit, multi-revolution 16-bit)					
Speed variation	±1 [r/min] max.: load deviation 0 to 100%					
	±1 [r/min] max.: power fluctuation -10 to +10%					
	±2% max.: temperature variation 25°C±10°C at rated speed (by analog voltage input)					
Speed control accuracy	1:5000 (at rated load)					
Frequency response	600Hz [Moment of load inertia converted into motor shaft (JL)= Moment of motor inertia (JM): 100% load]					
Max. moment of load inertia	100 times of the motor rotor inertia (velocity control type)					
Overload capability	300% for 3 sec, 400% for 1.5 sec			300% for 3 sec		
Additional functions	Braking	Regenerative braking, dynamic braking with external braking resistor				
	Protection	overcurrent (OC), overspeed (OS), low voltage (Lv), high voltage (Hv), encoder trouble (Et), control power trouble (Ct), data or memory error (dE), combination error (CE), regenerative transistor overheat (rH2), encoder communication error (EC), control signal error (CtE), motor overload (OL), regenerative resistor overheat (rH), excessive deviation (OF), amplifier overheat (AH), encoder overheat (EH), absolute data lost (AL), absolute data overflow (AF), fuse blown (Fb): 2kW or over				
	Display, setting	CHARGE lamp (red), 5-digit 7-segment LED, and 4 operation keys				
Working conditions	Installation place	For indoor use at max altitude of 1000 m. The installation place shall be free from dust, corrosive gas, or direct sunlight. To meet the European standard: Pollution degree = 2, Overvoltage category =				
	Temp., humidity	-10 to +55°C, 10 to 90% RH (without condensation)				
	Vibration / shock	4.9m/s <sup>2</sup> , 19.6m/s <sup>2</sup>				
Others	DC reactor terminals (P1, P+) for suppressing harmonics The amplifier complies with UL508c (UL/cUL) and EN50178 (European standard).					
Mass [kg]	2.0		4.6	4.7	5.2	5.2

\*1: The applied motor output shows capacity output by the standard combination.

\*2: The overload capacities 450% and 400% apply to the one-rank lower motors (the above amplifier is not usable for the 0.1kW slim type motor).

# SPECIFICATIONS

## SERVO AMPLIFIER (Single-phase 100V Series)

### Basic type

Amplifier type	RYS500S3-VVS6	RYS101S3-VVS6	RYS201S3-VVS6
Applicable motor output [kW]	0.05	0.1	0.2
Input	Phase	Single-phase for motor power, single-phase for control power	
	Voltage	100 to 115V -15% to 10%	
	Frequency	50/60Hz	
Control system	Sinusoidal PWM current control (full digital)		
Carrier frequency [kHz]	10		
Feedback	16-bit serial encoder (resolution/revolution 16-bit, multi-revolution 16-bit)		
Speed variation	±1 [r/min] max.: load deviation 0 to 100%		
	±1 [r/min] max.: power fluctuation -10 to +10%		
	±2% max.: temperature variation 25°C±10°C at rated speed (by analog voltage input)		
Speed control accuracy	1:5000 (at rated load)		
Frequency response	600Hz [Moment of load inertia converted into motor shaft (JL)= Moment of motor inertia (JM)]		
Max. moment of load inertia	100 times of the motor rotor inertia (velocity control type)		
Overload capability	300% for 3 sec		
Additional functions	Braking (*)	Regenerative braking, dynamic braking with external braking resistor	
	Protection	overcurrent (OC), overspeed (OS), low voltage (Lv), high voltage (Hv), encoder trouble (Et), control power trouble (Ct), data or memory error (dE), combination error (CE), regenerative transistor overheat (rH2), encoder communication error (EC), control signal error (CIE), motor overload (OL), regenerative resistor overheat (rH), excessive deviation (OF), amplifier overheat (AH), encoder overheat (EH), absolute data lost (AL), absolute data overflow (AF)	
	Display, setting	CHARGE lamp (red), 5-digit 7-segment LED, and 4 operation keys	
Working conditions	Installation place	For indoor use at max altitude of 1000 m. The installation place shall be free from dust, corrosive gas, or direct sunlight. To meet the European standard: Pollution degree = 2, Overvoltage category = II	
	Temp., humidity	-10 to +55°C, 10 to 90% RH (without condensation)	
	Vibration, shock	4.9m/s <sup>2</sup> , 19.6m/s <sup>2</sup>	
Others	DC reactor terminals (P1, P+) for suppressing harmonics, The amplifier complies with UL508c (UL/cUL) and EN50178 (European standard).		
Mass [kg]	0.9		1.2

\*1: The 0.2kW amplifier incorporates a DB resistor.

### Standard type for V type amplifier

Amplifier type	RYS□□□S3-VVS	Terminal symbol
Pulse train input	Max. input frequency: 500kHz (at differential input)	CA, *CA
Pulse train form	(1) Command pulse/code (2) Forward/reverse rotation pulse (3) Two 90° phase-different signals	CB, *CB
Frequency dividing output	Max. output frequency: 500kHz (at differential output)	FA, *FA
Freq. dividing output form	Two 90° phase-different signals	FB, *FB
Frequency dividing output pulses	16 to 16384 pulses/rev. (in increment of 1 pulse)	FZ, *FZ
Power source for speed command	+10±0.4V (max. output current: 30mA)	P10
Speed command input	±10V (input impedance: 20 kΩ)	NREF
Torque command input	±10V (input impedance: 20 kΩ)	TREF
Monitor output 1/2	For analog-meter (two-way/one-way deflection) (1) Speed command (2) Speed feedback (3) Torque command (4) Positional deviation	MON1 MON2
Power source for I/F	+24V DC, 300mA (supplied from external power source)	P24, M24
Control input	+24V DC, 10mA (one-point) source input Terminals to which control input signals are assigned	CONT1 to CONT8
OUT output	+30V DC, 50mA (max.) sink output Terminals to which control output signals are assigned	OUT1 to OUT5
External backup	Input terminal used to supply encoder backup power from external power source	BAT+, BAT-
Control functions	Control form	Position, speed, and torque control (selectable with control input signals)
	Position control	Pulse train, interruptive positioning, return to origin
	Origin setting	Origin limit switches, zero phase, and position preset
	Speed control	Analog voltage, multistep speed setting
	Torque control	Analog voltage
	Other functions	Override, brake timing output, etc.

### Standard type for L type amplifier

Amplifier type	RYS□□□S3-LPS	Terminal symbol
Pulse train input	Max. input frequency: 500kHz (at differential input)	CA, *CA
Pulse train form	(1) Command pulse/code (2) Forward/reverse rotation pulse (3) Two 90° phase-different signals	CB, *CB
Frequency dividing output	Max. output frequency: 500kHz (at differential output)	FA, *FA
Freq. dividing output form	Two 90° phase-different signals	FB, *FB
Frequency dividing output pulses	16 to 16384 pulses/rev. (in increment of 1 pulse)	FZ, *FZ
Power source for speed command	+10±0.4V (max. output current: 30mA)	P10
Speed command input	±10V (input impedance: 20 kΩ)	NREF
Monitor output 1/2	For analog-meter (two-way/one-way deflection) (1) Speed command (2) Speed feedback (3) Torque command (4) Positional deviation	MON1 MON2
Power source for I/F	+24V DC, 300mA (supplied from external power source)	P24, M24
Control input	+24V DC, 10mA (one-point) source input Terminals to which control input signals are assigned	CONT1 to CONT21
OUT output	+30V DC, 50mA (max.) sink output Terminals to which control output signals are assigned	OUT1 to OUT10
External backup	Input terminal used to supply encoder backup power from external power source	BAT+, BAT-
Control functions	Position control	Auto start (address designation, sequential start, immediate positioning) Manual operation (analog voltage, multistep speed setting, interruptive positioning) Pulse train input, return to origin (4 patterns)
	Origin setting	Origin limit switches, zero phase, and position preset
	No. of position data sets	99 points (position, speed, timer, M code and various statuses)
	Max positioning value	±79,999,999 (x unit amount)
	Additional functions	Override, brake timing output, etc.

### Standard type for R type amplifier

Amplifier type	RYS□□□S3-RPS	Terminal symbol
Pulse train input	Max. input frequency: 500kHz (at differential input)	CA, *CA
Pulse train form	(1) Command pulse/code (2) Forward/reverse rotation pulse (3) Two 90° phase-different signals	CB, *CB
Frequency dividing output	Max. output frequency: 500kHz (at differential output)	FA, *FA
Freq. dividing output form	Two 90° phase-different signals	FB, *FB
Frequency dividing output pulses	16 to 16384 pulses/rev. (in increment of 1 pulse)	FZ, *FZ
Power source for speed command	+10±0.4V (max. output current: 30mA)	P10
Speed command input	±10V (input impedance: 20 kΩ)	NREF
Monitor output 1/2	For analog-meter (two-way/one-way deflection) (1) Speed command (2) Speed feedback (3) Torque command (4) Positional deviation	MON1 MON2
Power source for I/F	+24V DC, 300mA (supplied from external power source)	P24, M24
Control input	+24V DC, 10mA (one-point) source input Terminals to which control input signals are assigned	CONT1 to CONT21
OUT output	+30V DC, 50mA (max.) sink output Terminals to which control output signals are assigned	OUT1 to OUT10
External backup	Input terminal used to supply encoder backup power from external power source	BAT+, BAT-
Control functions	Position control	Auto start (station designation), Manual operation (analog voltage, multistep speed setting, manual indexing), Pulse train input, return to origin
	Origin setting	Origin limit switches, zero phase, and position preset
	No. of divisions	30000
	Speed reduction ratio	α/β (α=1 to 9999, β=1 to 9999 in increments of 1)
	Additional functions	Override, brake timing output, 2nd origin effective, etc.

# SERVO AMPLIFIER

## ■ For amplifier directly connected to SX bus

Amplifier type	RYS□□□S3-□SS	Terminal symbol
SX bus	IQ area, 16 words	(IN, OUT)
Pulse train input	(*1) Max. input frequency: 500kHz (at differential input)	CA, *CA
Pulse train form	(*1) (1) Command pulse/code (2) Forward/reverse rotation pulse (3) Two 90° phase-different signals	CB, *CB
Power source for pulse train	5 V DC, 200mA (max.)	P5
Frequency dividing output	Max. output frequency: 500kHz (at differential output)	FA, *FA
Freq. dividing form	Two 90° phase-different signals	FB, *FB
Frequency dividing output pulses	16 to 16384 pulses/rev. (in increment of 1 pulse)	FZ, *FZ
Power source for speed command	---	---
Speed command input	---	---
Torque command input	---	---
Monitor output 1/2	For analog-meter (two-way/one-way deflection). (1) Speed command (2) Speed feedback (3) Torque command (4) Positional deviation	MON1 MON2
Power source for I/F	+24V DC, 300mA (supplied from external power source)	P24, M24
Control input	+24V DC, 10mA (one-point) source input External control input terminals	CONT1 to CONT5
OUT output	+30V DC, 50mA (max.) sink output External control output terminals	OUT1 and OUT2
External backup	Input terminals used to supply encoder backup power from external power source	BAT+ BAT-
Control functions	V type: Depends on MICREX-SX FB L type: Same with DI/DO specifications (RYS-LPS) R type: Same with DI/DO specifications (RYS-RPS)	

\*1: type does not have a pulse train input terminal.

## ■ For amplifier directly connected to T-link

Amplifier type	RYS□□□S3-□TS	Terminal symbol
T link	B area, 8 words	(T2, T1, SD)
Pulse train input	Max. input frequency: 500kHz (at differential input)	CA, *CA
Pulse train form	(1) Command pulse/code (2) Forward/reverse rotation pulse (3) Two 90° phase-different signals	CB, *CB
Power source for pulse train	5 V DC, 200mA (max.)	P5
Frequency dividing output	Max. output frequency: 200kHz (open collector)	
Freq. dividing form	Two 90° phase-different signals	FA, FB, FZ
Frequency dividing output pulses	16 to 16384 pulses/rev. (in increment of 1 pulse)	
Power source for speed command	---	---
Speed command input	---	---
Monitor output 2	For analog-meter (two-way/one-way deflection). (1) Speed command (2) Speed feedback (3) Torque command (4) Positional deviation	MON2
Power source for I/F	+24V DC, 100mA (supplied from external power source)	P24, M24
Control input	+24V DC, 10mA (one-point) source input External control input terminals	CONT1 to CONT8
OUT output	+30V DC, 50mA (max.) sink output External control output terminals	OUT1 to OUT4
External backup	Input terminals used to supply encoder backup power from external power source	BAT+
Control functions	L type: Same with DI/DO specifications (RYS-LPS) R type: Same with DI/DO specifications (RYS-RPS)	

## ■ For amplifier directly connected to RS485

Amplifier type	RYS□□□S3-□RS	Terminal symbol
RS485	4-wire, half duplex system (max. 31 stations)	---
Pulse train input	Max. input frequency: 500kHz (at differential input)	CA, *CA
Pulse train form	(1) Command pulse/code (2) Forward/reverse rotation pulse (3) Two 90° phase-different signals	CB, *CB
Power source for pulse train	5 V DC, 200mA (max.)	P5
Frequency dividing output	Max. output frequency: 200kHz (open collector)	
Freq. dividing form	Two 90° phase-different signals	FA, FB, FZ
Frequency dividing output pulses	16 to 16384 pulses/rev. (in increment of 1 pulse)	
Power source for speed command	---	---
Speed command input	---	---
Torque command input	---	---
Monitor output 2	For analog-meter (two-way/one-way deflection). (1) Speed command (2) Speed feedback (3) Torque command (4) Positional deviation	MON2
Power source for I/F	+24V DC, 100mA (supplied from external power source)	P24, M24
Control input	+24V DC, 10mA (one-point) source input External control input terminals	CONT1 to CONT8
OUT output	+30V DC, 50mA (max.) sink output External control output terminals	OUT1 to OUT4
External backup	Input terminals used to supply encoder backup power from external power source	BAT+
Control functions	L type: Same with DI/DO specifications (RYS-LPS)	

## 3-phase 200V series

### [V type] Standard

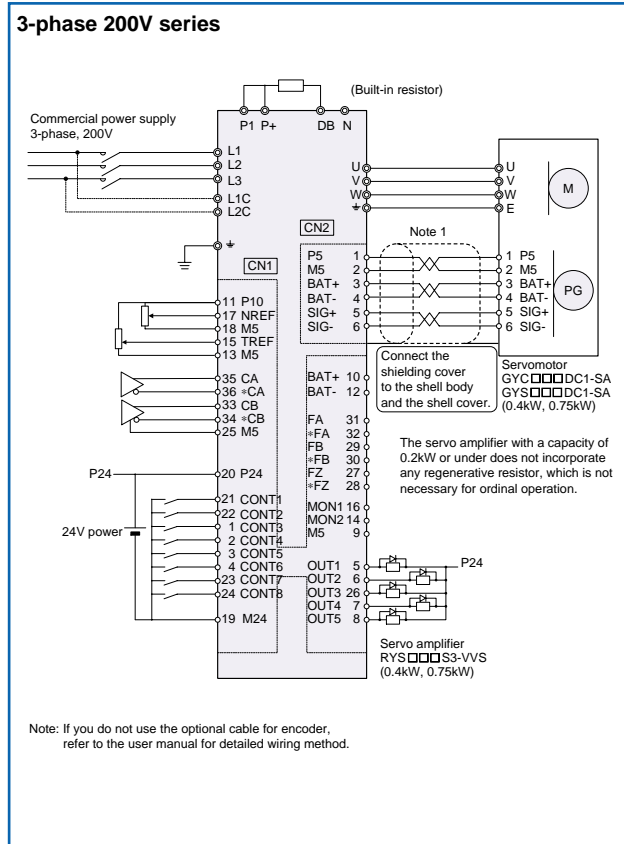

### [L, R type] Standard

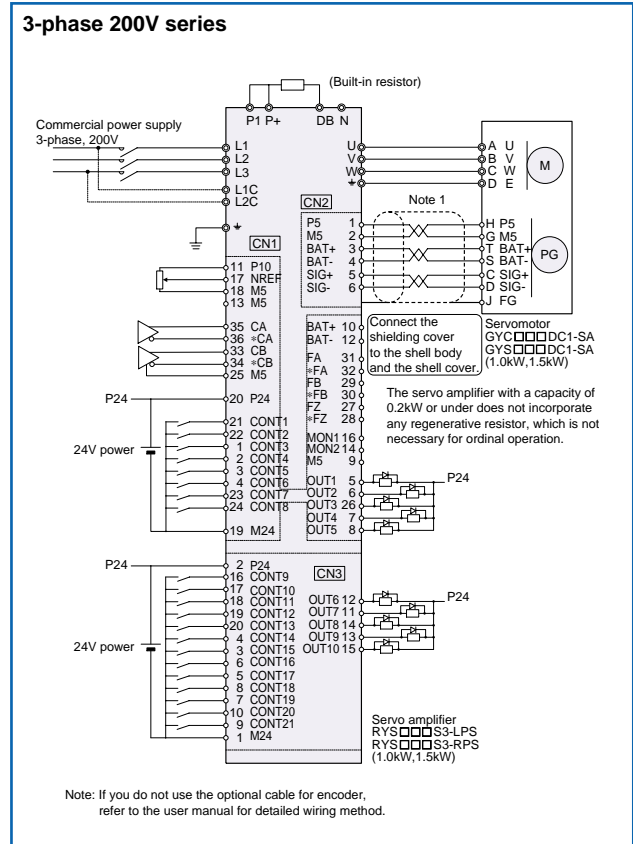

### [V type] Direct connection with SX bus

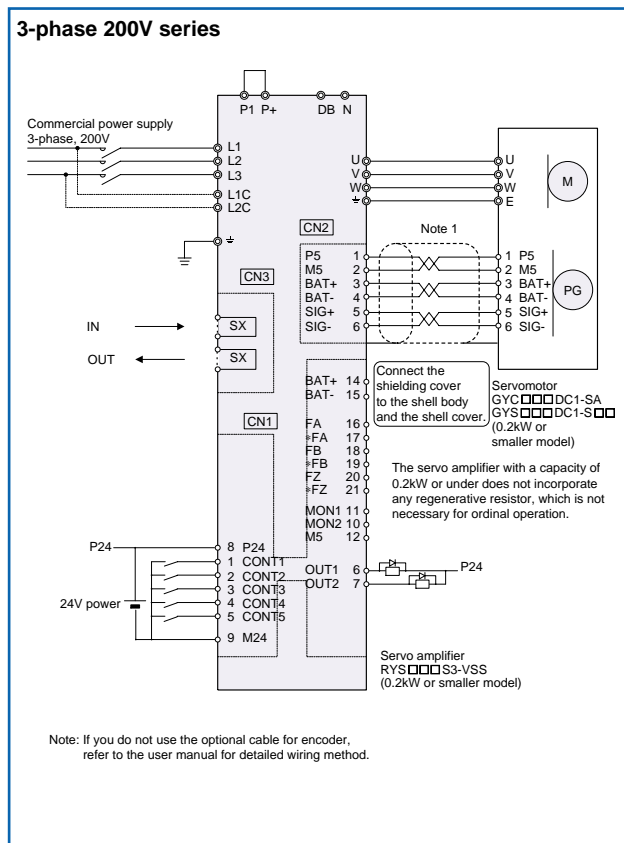

### [L, R type] Direct connection with SX bus

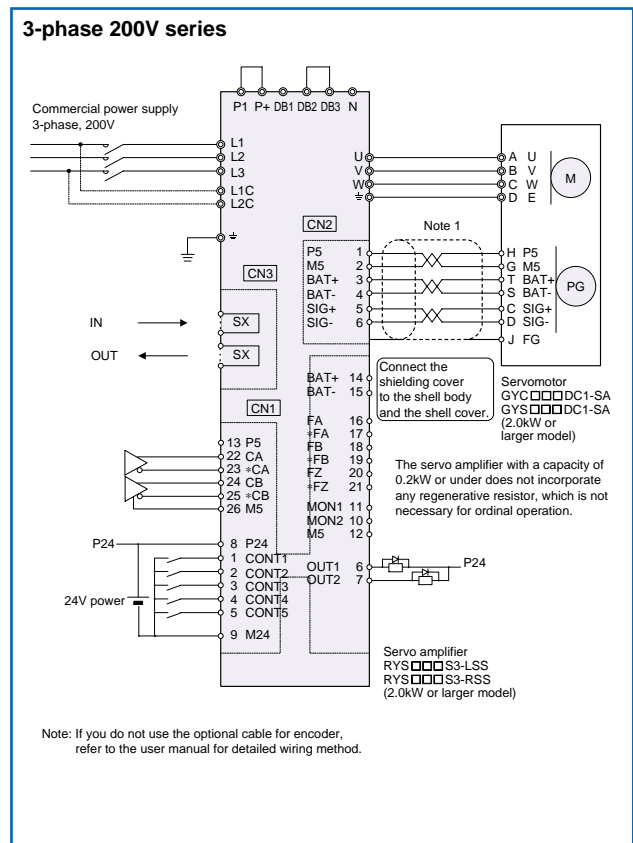

# 3-phase 200V, Single-phase 100V series

## [L, R type ]Direct connection with T-link

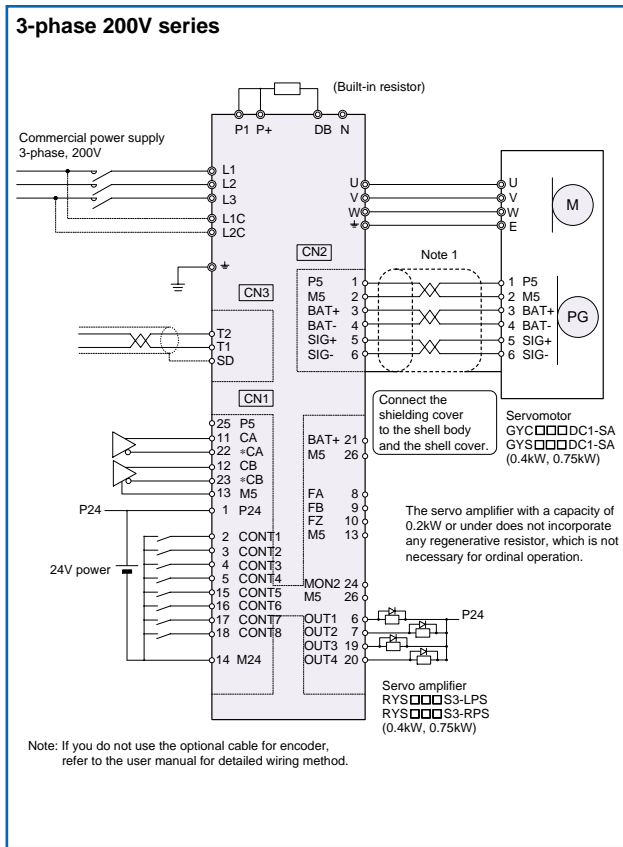

## [L, R type ]Direct connection with RS485

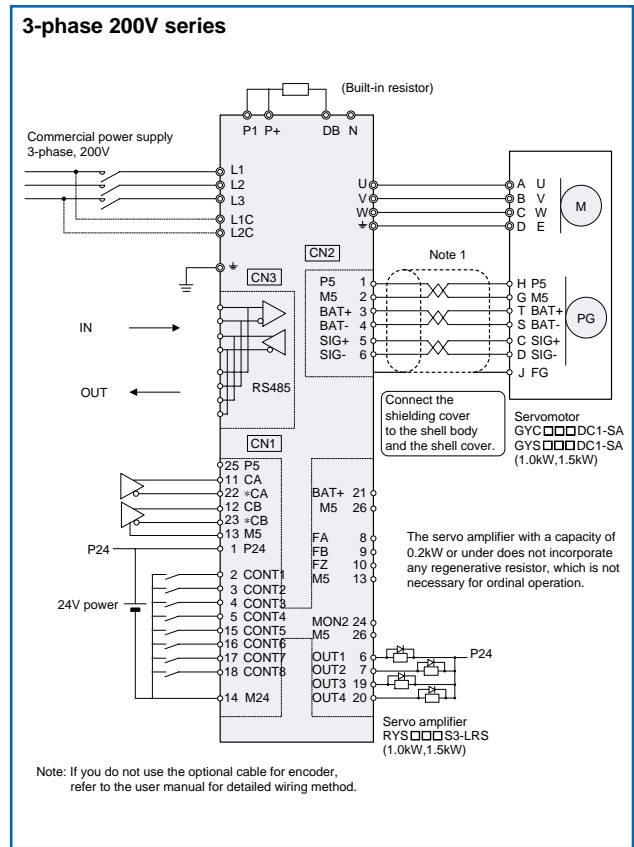

## [V type ]DI/DO

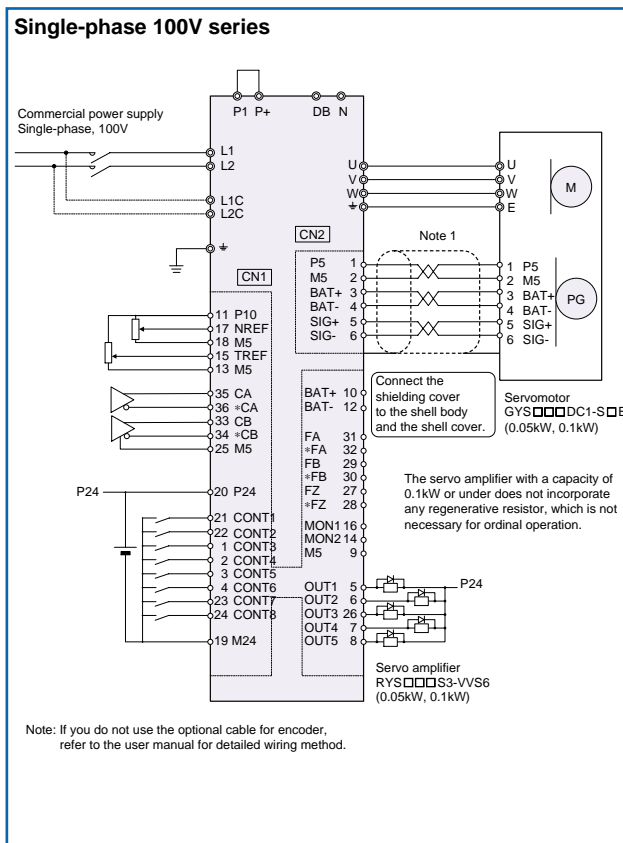

**CAUTION**

The above diagram is given as a reference for model selection. When actually using the selected servo system, make wiring connections according to the connection diagram and instructions described in the user's manual.

# EXTERNAL DIMENSIONS

## 200V series

### [Cubic type]

Series: GYC series motor of standard type

Type: GYC101DC1-SA to GYC202DC1-SA

Capacity range: 0.1 to 2.0kW

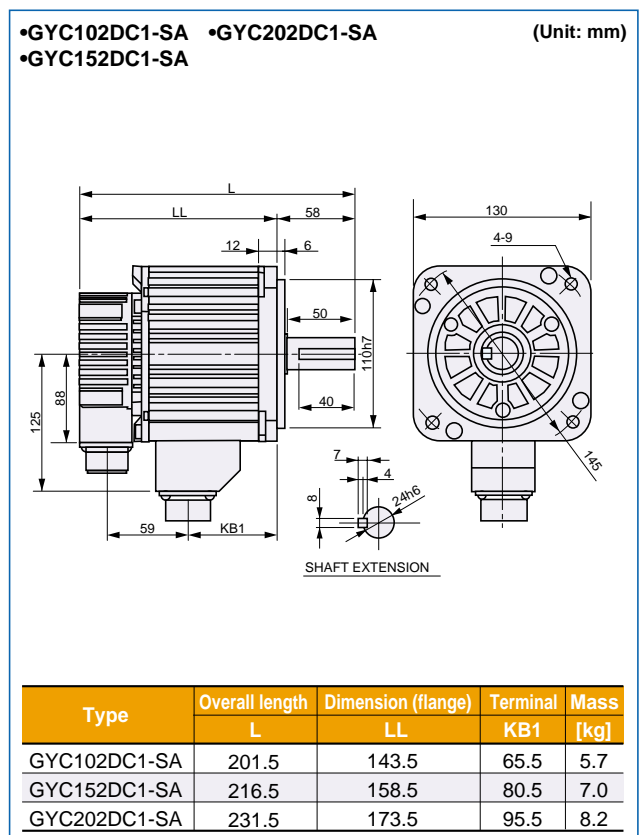
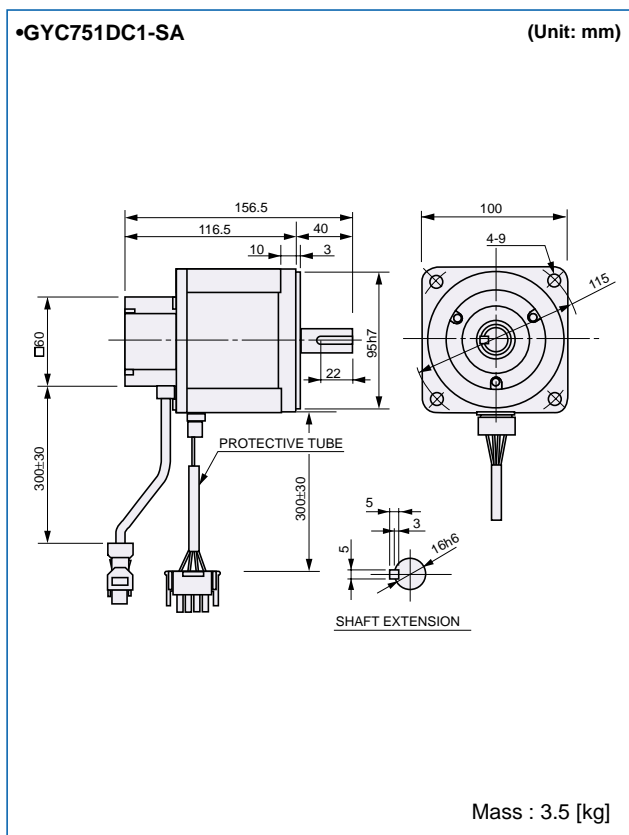
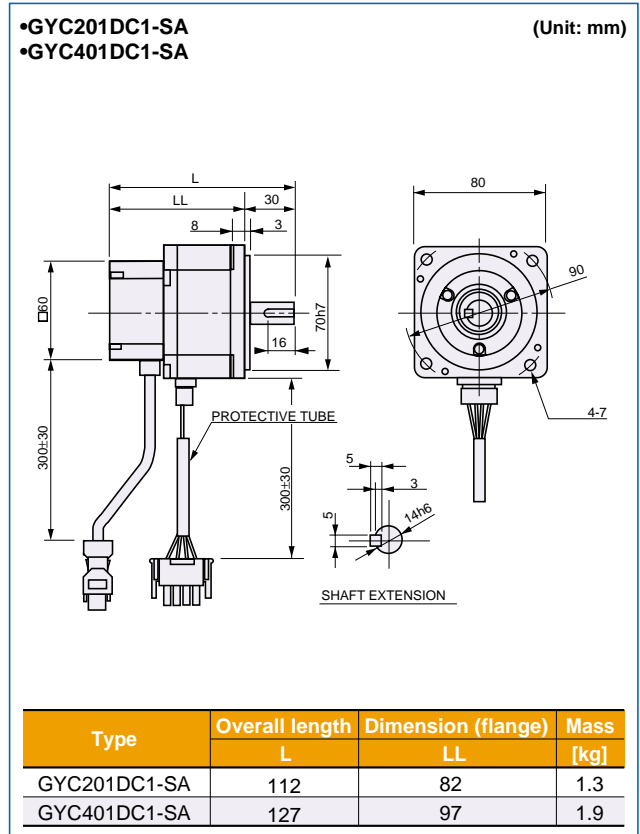
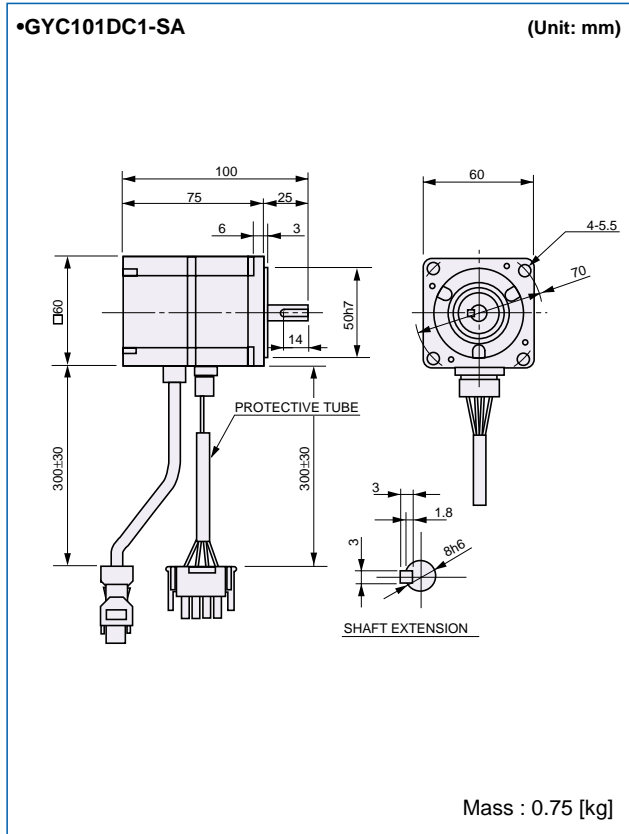

**[Cubic type]**

**Series:** GYC series motor with a brake

**Type:** GYC101DC1-SA-B to GYC202DC1-SA-B

**Capacity range:** 0.1 to 2.0kW

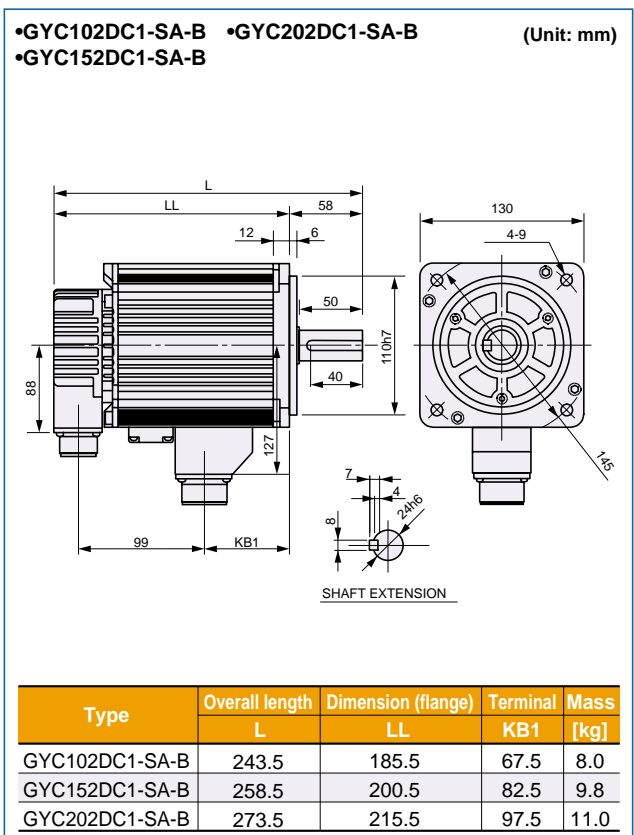
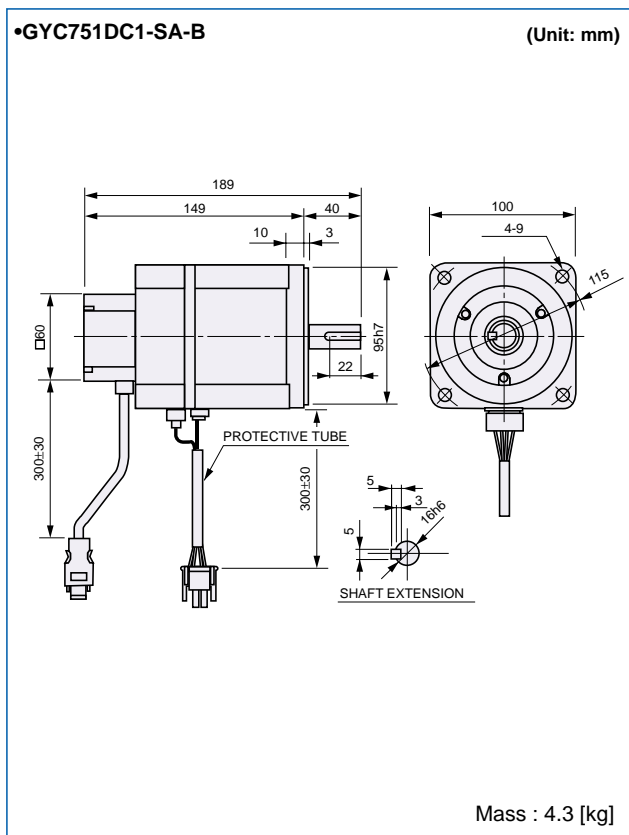
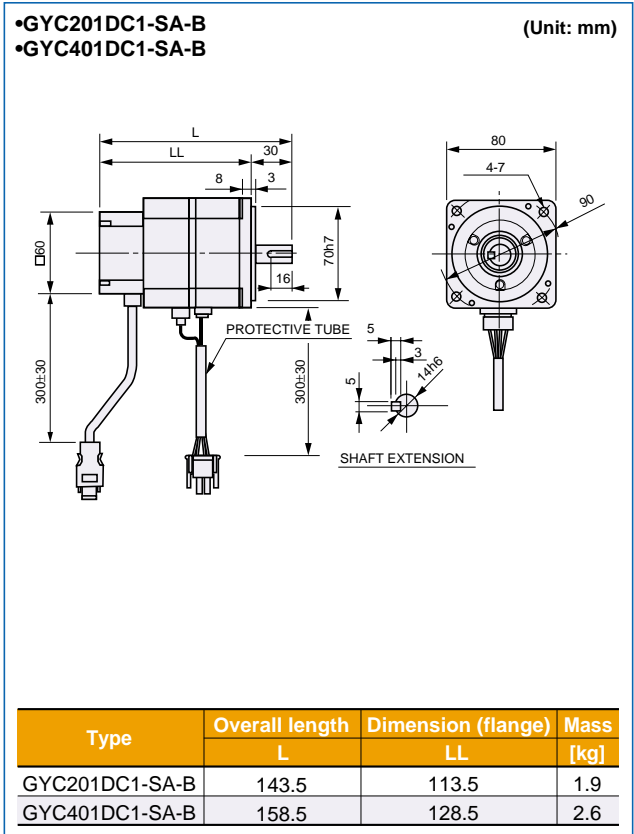
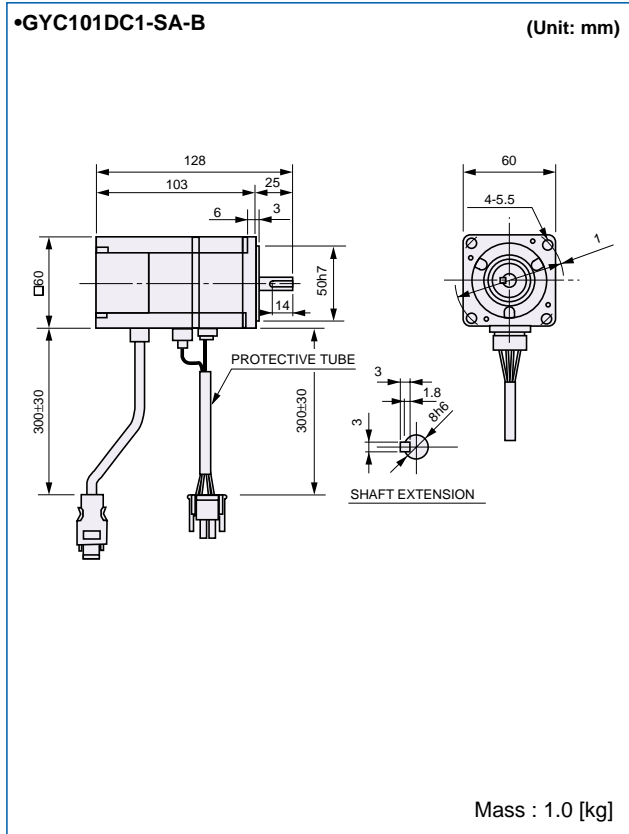

# EXTERNAL DIMENSIONS

## 200V / 100V series

### [Slim type]

Series: GYS series motor of standard type  
 Type: GYS500DC1-S8B to GYS502DC1-SA  
 Capacity range: 0.05 to 5.0kW

•GYS500DC1-S8B (200V / 100V series)  
 •GYS101DC1-SB (200V series) •GYS101DC1-S6B (100V series)  
 (Unit: mm)

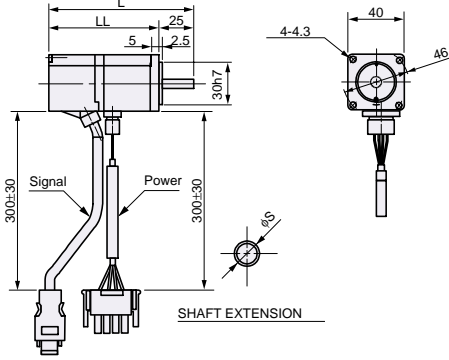

Type	Shaft end shape φS	Overall length L	Dimension (flange) LL	Mass [kg]
GYS500DC1-S8B*	6h6	103	78	0.45
GYS101DC1-SB	8h6	121	96	0.55
GYS101DC1-S6B	8h6	121	96	0.55

\*100V series has the same dimensions.

Series: GYS series motor of standard type  
 Type: GYS500DC1-S8B to GYS201DC1-S6B  
 Capacity range: 0.05 to 0.2kW

•GYS201DC1-SA (200V series) •GYS201DC1-S6B (100V series)  
 •GYS401DC1-SA (200V series)  
 (Unit: mm)

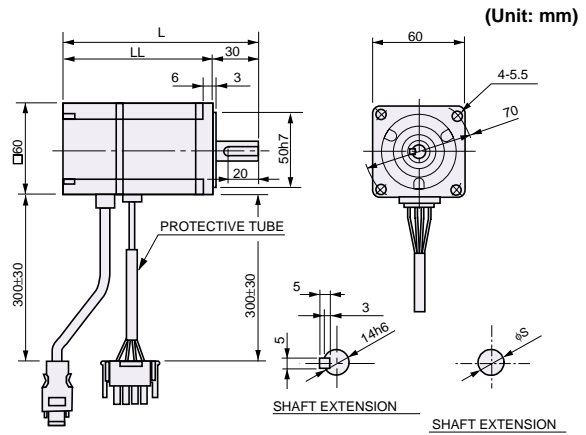

Type	Overall length L	Dimension (flange) LL	Mass [kg]
GYS201DC1-SA	126.5	96.5	1.2
GYS401DC1-SA	154.5	124.5	1.8
GYS201DC1-S6B	126.5	96.5	1.2

•GYS751DC1-SA (Unit: mm)

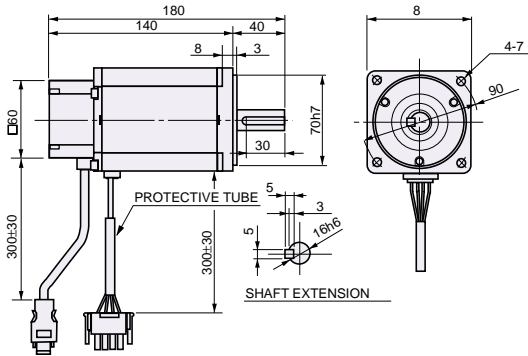

Mass : 3.4 [kg]

•GYS102DC1-SA •GYS202DC1-SA (Unit: mm)  
 •GYS152DC1-SA

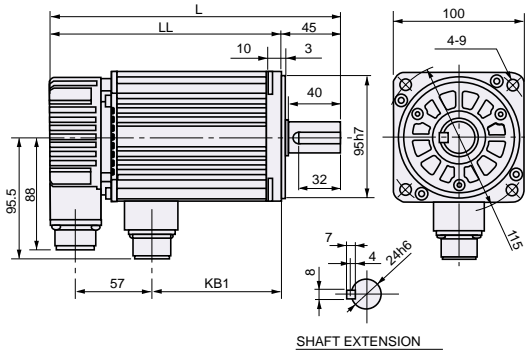

Type	Overall length L	Dimension (flange) LL	Terminal KB1	Mass [kg]
GYS102DC1-SA	198	153	77	4.4
GYS152DC1-SA	220.5	175.5	99.5	5.2
GYS202DC1-SA	243	198	122	6.3

•GYS302DC1-SA •GYS502DC1-SA (Unit: mm)  
 •GYS402DC1-SA

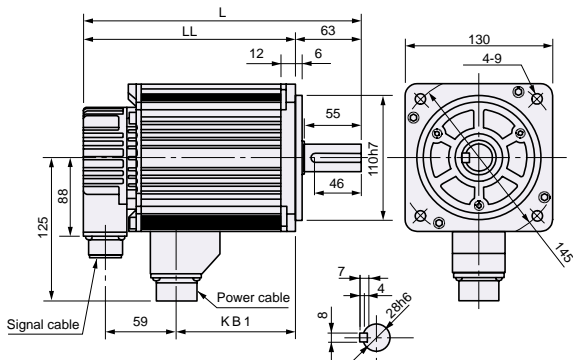

Type	Overall length L	Dimension (flange) LL	Terminal KB1	Mass [kg]
GYS302DC1-SA	266.5	203.5	122.5	11.0
GYS402DC1-SA	296.5	233.5	155.5	13.5
GYS502DC1-SA	326.5	263.5	185.5	16.0

**[Slim type]**

**Series:** GYS series motor with a brake  
**Type:** GYS500DC1-S8B-B to GYS502DC1-SA-B  
**Capacity range:** 0.05 to 5.0kW

- GYS500DC1-S8B-B (200V / 100V series)
- GYS101DC1-SB-B (200V series)
- GYS101DC1-S6B-B (100V series)

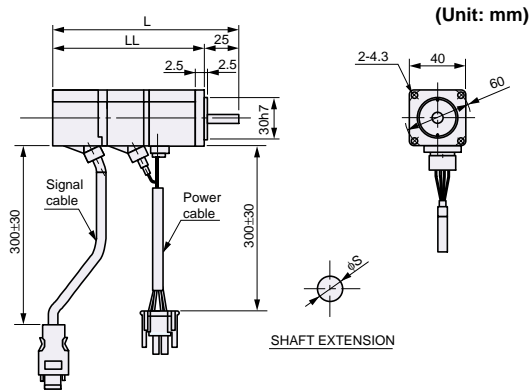

Type	Shaft end shape $\phi$ S	Overall length		Dimension (flange) LL	Mass [kg]
		L	LL		
GYS500DC1-S8B-B*	6h6	140	115	0.6	
GYS101DC1-SB-B	8h6	158	133	0.7	
GYS101DC1-S6B-B	8h6	158	133	0.7	

\*100V series has the same dimensions.

**Series:** GYS series motor with a brake  
**Type:** GYS500DC1-S8B-B to GYS201DC1-S6B-B  
**Capacity range:** 0.05 to 0.2kW

- GYS201DC1-SA-B (200V series)
- GYS201DC1-S6B-B (100V series)
- GYS401DC1-SA-B (200V series)

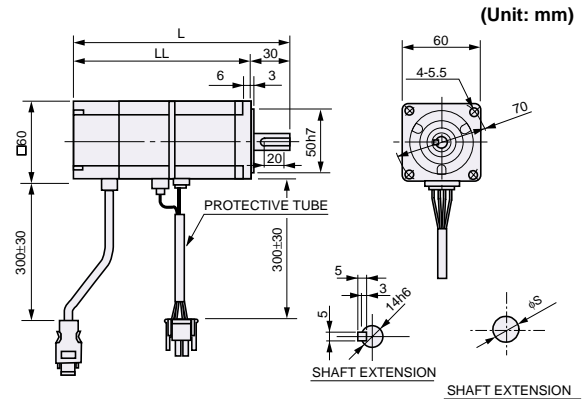

Type	Overall length		Dimension (flange) LL	Mass [kg]
	L	LL		
GYS201DC1-SA-B	165	135	1.7	
GYS401DC1-SA-B	193	165	2.3	
GYS201DC1-S6B-B	165	135	1.7	

- GYS751DC1-SA-B (Unit: mm)

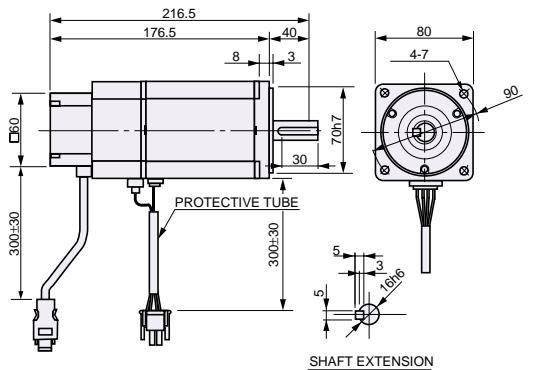

Mass : 4.2 [kg]

- GYS102DC1-SA-B
- GYS202DC1-SA-B
- GYS152DC1-SA-B (Unit: mm)

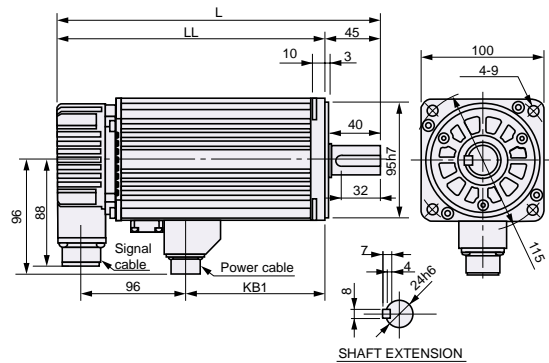

Type	Overall length		Dimension (flange) LL	Terminal KB1	Mass [kg]
	L	LL			
GYS102DC1-SA-B	239	194	79	5.9	
GYS152DC1-SA-B	261.5	216.5	101.5	6.8	
GYS202DC1-SA-B	284	239	124	7.9	

- GYS302DC1-SA-B
- GYS502DC1-SA-B
- GYS402DC1-SA-B (Unit: mm)

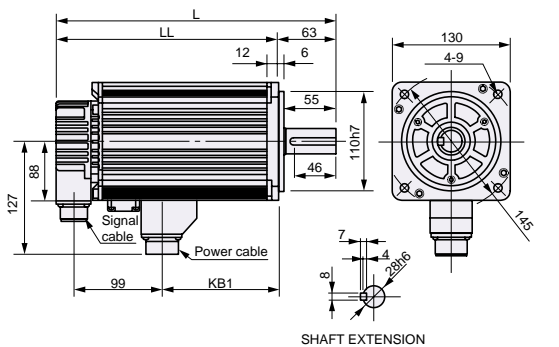

Type	Overall length		Dimension (flange) LL	Terminal KB1	Mass [kg]
	L	LL			
GYS302DC1-SA-B	308.5	245.5	127.5	13.0	
GYS402DC1-SA-B	338.5	275.5	157.5	15.5	
GYS502DC1-SA-B	368.5	305.5	187.5	18.0	

# EXTERNAL DIMENSIONS

## 200V series

### [Cubic type]

Series: Gear head for GYC series motor

Type: GYN101CAG-G09 to GYN202CAG-G09

Capacity range: 0.1 to 2.0kW

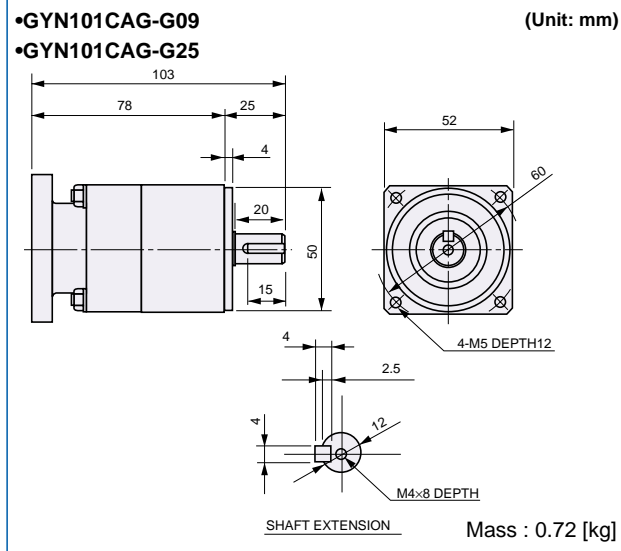

Series: Gear head for GYC series motor

Type: GYN101CAG-G25 to GYN202CAG-G15

\* For 1.0 kW or larger capacity model, the reduction ratio is 1/15.

Capacity range: 0.1 to 2.0kW

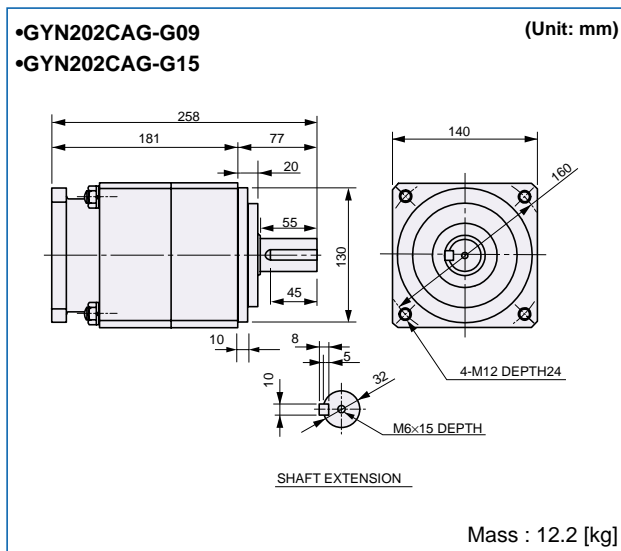
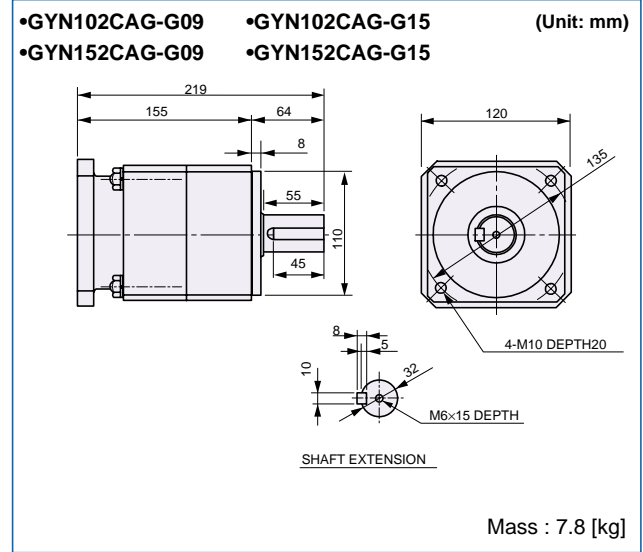
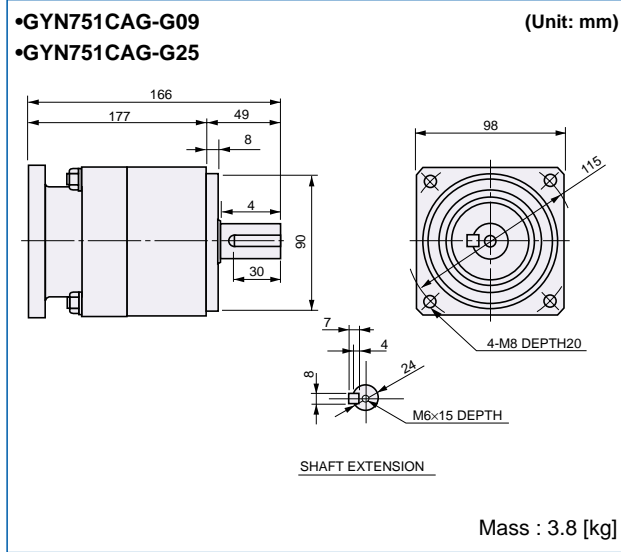
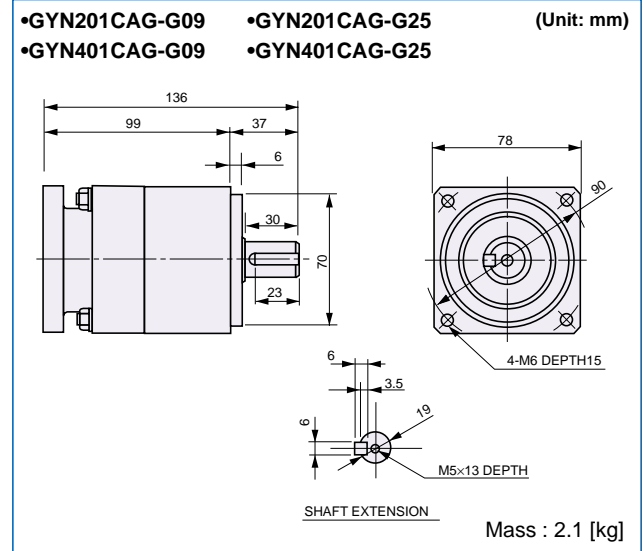

**[Slim type]**

**Series:** Gear head for GYS series motor

**Type:** GYN500SAG-G09 to GYN202SAG-G09

**Capacity range:** 0.05 to 2.0kW

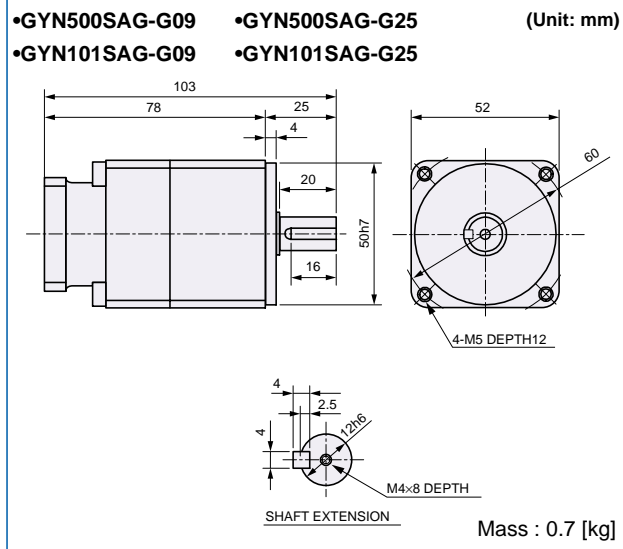

**Series:** Gear head for GYS series motor

**Type:** GYN500SAG-G25 to GYN202SAG-G15

\* For 1.0 kW or larger capacity models, the reduction ratio is 1/15.

**Capacity range:** 0.05 to 2.0kW

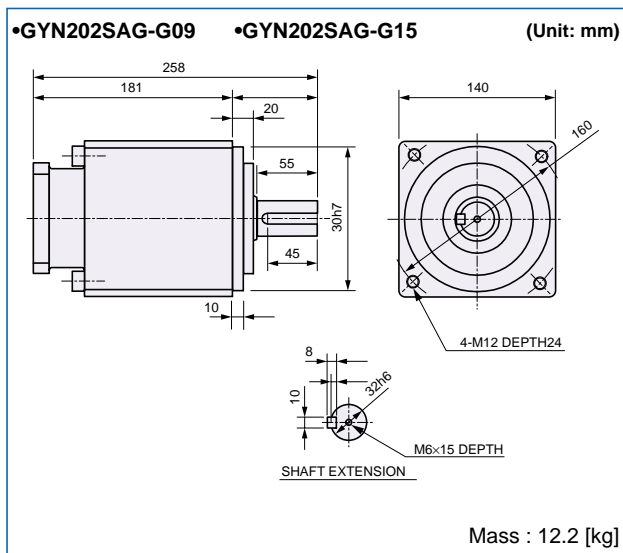
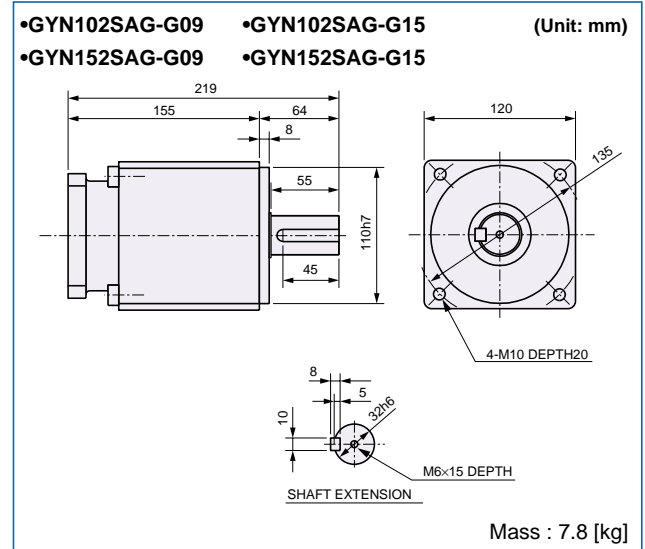
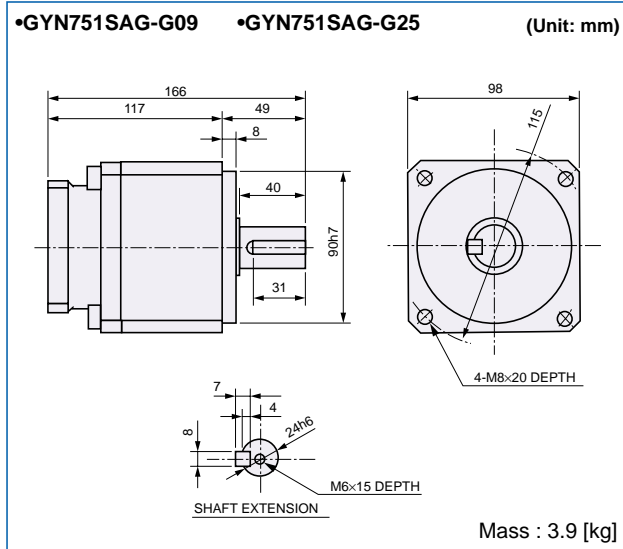
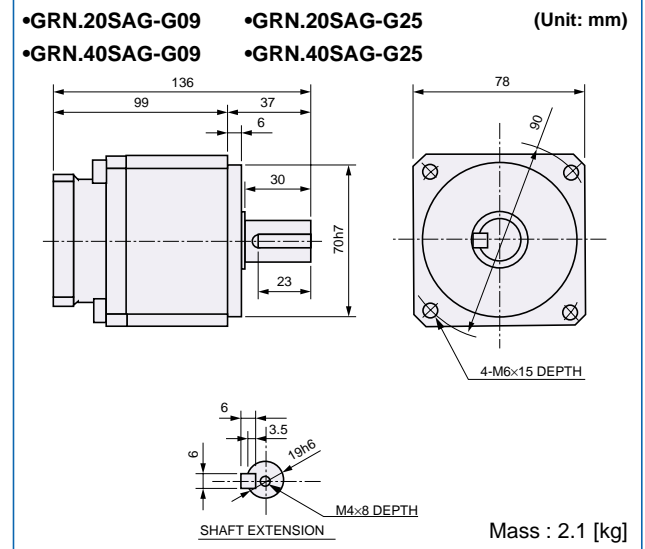

# EXTERNAL DIMENSIONS

## 3-phase 200V, Single-phase 100V series

[ Series ] RYS series servo amplifier

[ Type ] RYS500S3-□□S to RYS152S3-□□S, (RYS500S3-VVS6 to RYS201S3-VVS6)

\*Types and capacities in ( ) are for single-phase 100V series.

Capacity range : 0.05 to 0.2kW (0.05, 0.1kW)

(Unit: mm)

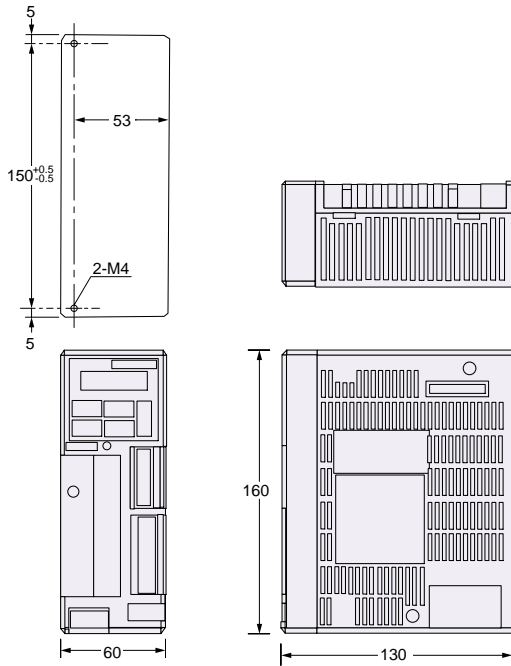

Capacity range : 0.4kW (0.2kW)

(Unit: mm)

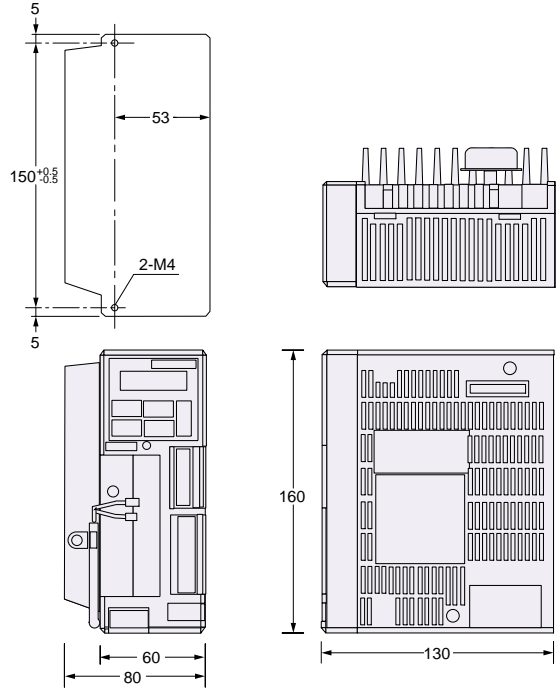

Capacity range : 0.75kW

(Unit: mm)

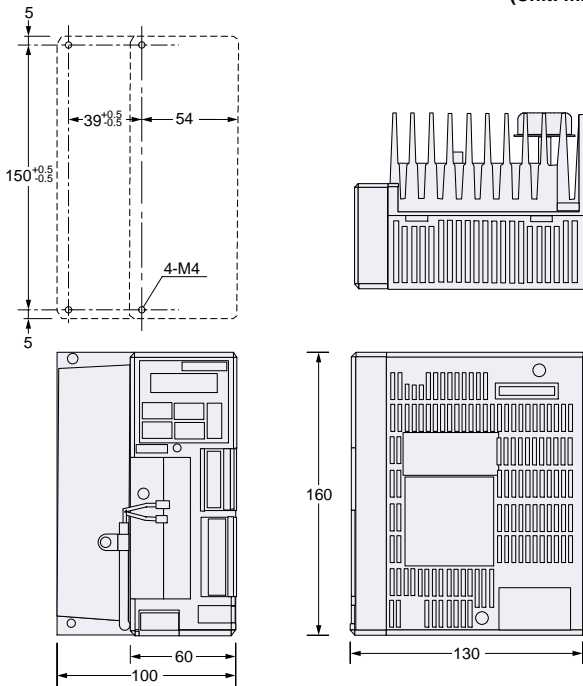

Capacity range : 1.0, 1.5kW

(Unit: mm)

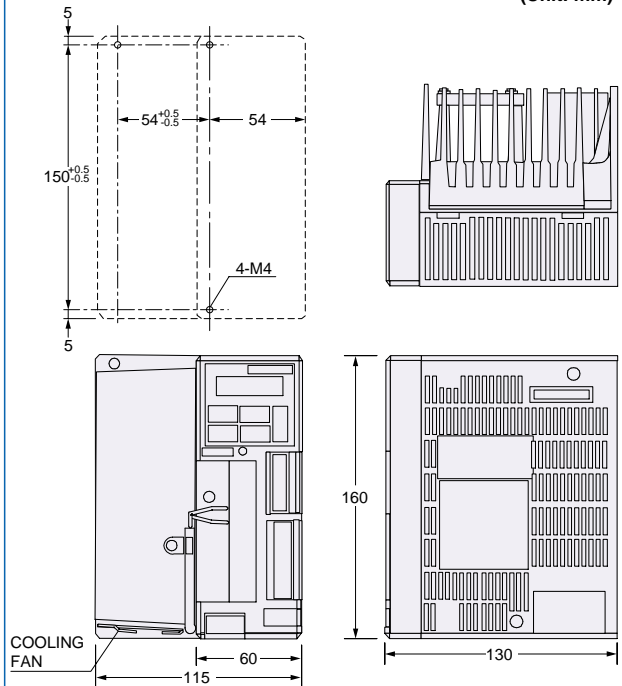

**[ Series ]** RYS series servo amplifier

**[ Type ]** RYS202S3-□□S to RYS502S3-□□S

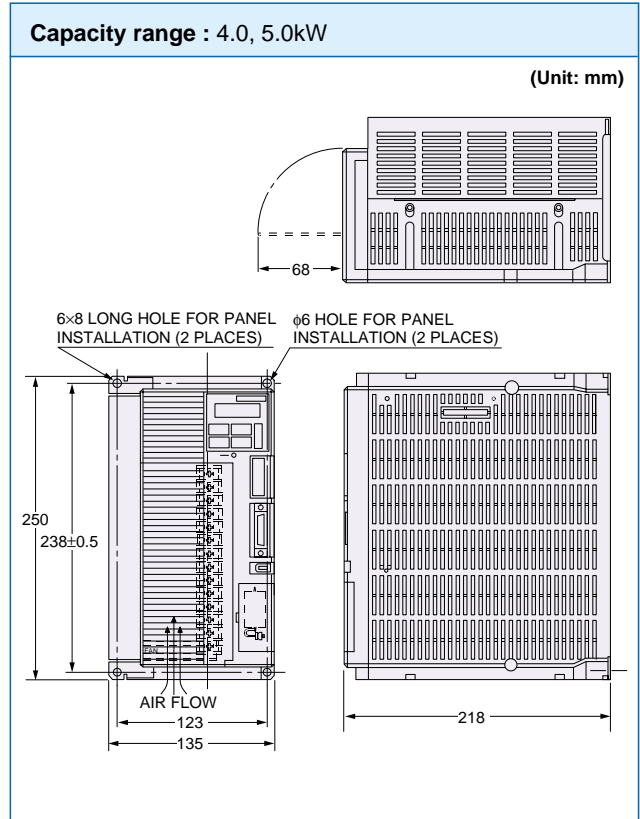
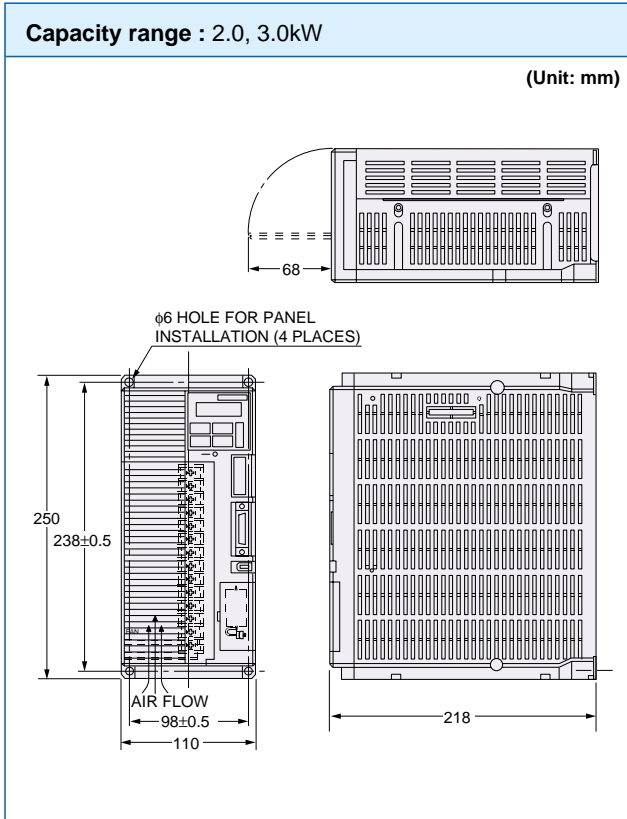

## Option

**Series:** Cable for input/output of control signals  
(extended I/O for L and R types)

**Type:** WSC-D20P03

**Applicable amplifier:** RYS□□□S3-LPS and RPS (CN3)

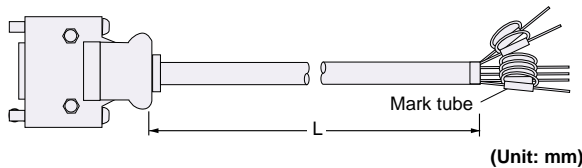

Type	L
WSC-D20P03	3000 <sup>+300</sup> / <sub>0</sub>

**Series:** Cable for input/output of control signals  
(directly connected to SX bus)

**Type:** WSC-D26P03

**Applicable amplifier:** RYS□□□S3-VSS, LSS, and RSS (CN1)

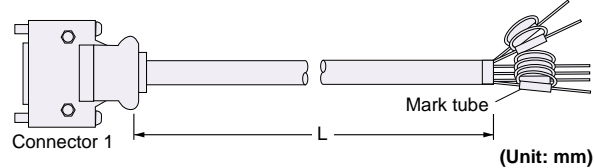

Type	L
WSC-D26P03	3000 <sup>+300</sup> / <sub>0</sub>

**Series:** Option cable for input/output of control signals  
(directly connected to SX bus)

**Type:** WSC-D36P03

**Applicable amplifier:** RYS□□□S3-VSS, LPS, and RPS (CN1)

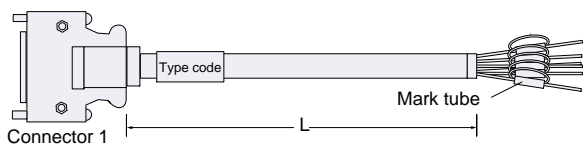

Type	L
WSC-D36P03	3000 <sup>+300</sup> / <sub>0</sub>

**Series:** Cable for servomotor encoder

**Type:** WSC-P06P05 to WSC-P06P20

**Application range:** 0.75kW or less

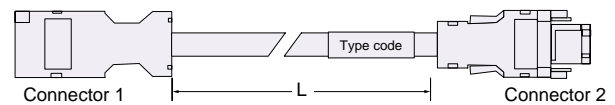

Type	L
WSC-P06P05	5000 <sup>+500</sup> / <sub>0</sub>
WSC-P06P10	10000 <sup>+1000</sup> / <sub>0</sub>
WSC-P06P20	20000 <sup>+2000</sup> / <sub>0</sub>

# EXTERNAL DIMENSIONS

## Option

**Series:** Cable for servomotor encoder  
**Type:** WSC-P06P05-C to WSC-P06P20-C  
**Application range:** 1.0kW or over

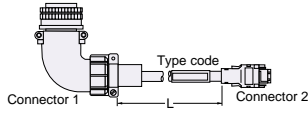

Type	L (Unit: mm)
WSC-P06P05-C	5000 <sup>+500</sup> <sub>0</sub>
WSC-P06P10-C	10000 <sup>+1000</sup> <sub>0</sub>
WSC-P06P20-C	20000 <sup>+2000</sup> <sub>0</sub>

**Series:** Cable for servomotor encoder  
**Type:** WSC-P06P05-W to WSC-P06P20-W  
**Application range:** All models

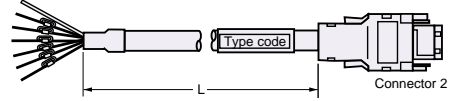

Type	L (Unit: mm)
WSC-P06P05-W	5000 <sup>+500</sup> <sub>0</sub>
WSC-P06P10-W	10000 <sup>+1000</sup> <sub>0</sub>
WSC-P06P20-W	20000 <sup>+2000</sup> <sub>0</sub>

**Series:** Option cable for distributing power to the servomotor  
**Type:** WSC-M04P05 to WSC-M04P20  
**Application range:** 0.75kW or less

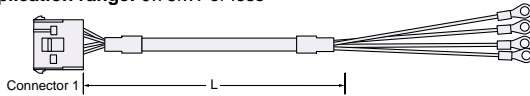

Type	L (Unit: mm)
WSC-M04P05	5000 <sup>+500</sup> <sub>0</sub>
WSC-M04P10	10000 <sup>+1000</sup> <sub>0</sub>
WSC-M04P20	20000 <sup>+2000</sup> <sub>0</sub>

**Series:** Power cable for servomotor (with brake)  
**Type:** WSC-P06P05-W to WSC-M06P20  
**Application range:** 0.75kW or less

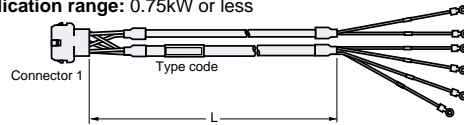

Type	L (Unit: mm)
WSC-M06P05	5000 <sup>+500</sup> <sub>0</sub>
WSC-M06P10	10000 <sup>+1000</sup> <sub>0</sub>
WSC-M06P20	20000 <sup>+2000</sup> <sub>0</sub>

**Series:** External regenerative resistor  
**Type:** WRS-401  
**Application range:** RYS type servo amplifier with a capacity of 0.4 kW or less

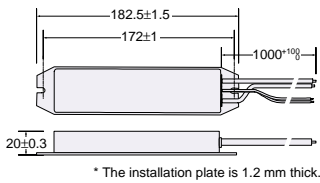

\* The installation plate is 1.2 mm thick.

Item	Specifications	
Type	WSR-401	
Resistor	Resistance	68Ω
	Allowable power	17W (continuous)
	Working temperature	Opens at 135±5°C
Thermistor	Withstand voltage	1.5kV AC for 1 minute
	Contact capacity	30V DC, 3A

**Series:** External regenerative resistor  
**Type:** WSR-152  
**Application range:** RYS type servo amplifier with a capacity of 1.0 or 1.5kW

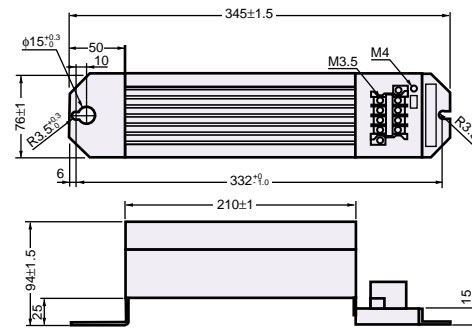

Item	Specifications	
Type	WSR-152	
Resistor	Resistance	15Ω
	Allowable power	75W (continuous)
	Working temperature	Opens at 150±10°C
Thermistor	Withstand voltage	2.5kV AC for 1 minute
	Contact capacity	30V DC, 3A

**Series:** External regenerative resistor  
**Type:** WRS-751  
**Application range:** RYS type servo amplifier with a capacity of 0.75kW

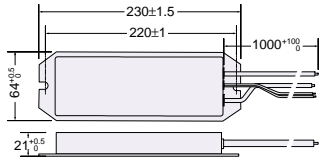

\* The installation plate is 1.5 mm thick.

Item	Specifications	
Type	WSR-751	
Resistor	Resistance	15Ω
	Allowable power	25W (continuous)
	Working temperature	Opens at 135±5°C
Thermistor	Withstand voltage	2.5kV AC for 1 minute
	Contact capacity	30V DC, 3A

**Series:** External regenerative resistor  
**Type:** DB11-2  
**Application range:** RYS type servo amplifier with a capacity of 2.0 or 3.0kW

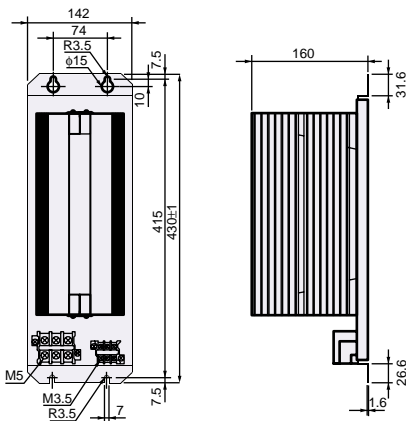

Item	Specifications	
Type	DB11-2	
Resistor	Resistance	10Ω
	Allowable power	115W (continuous)
	Working temperature	Opens at 150±10°C
Thermistor	Withstand voltage	2.5kV AC for 1 minute
	Contact capacity	120V AC, 0.1A/30V DC, 0.1A

**Series:** External regenerative resistor  
**Type:** DB22-2  
**Application range:** RYS type servo amplifier with a capacity of 4.0 or 5.0kW

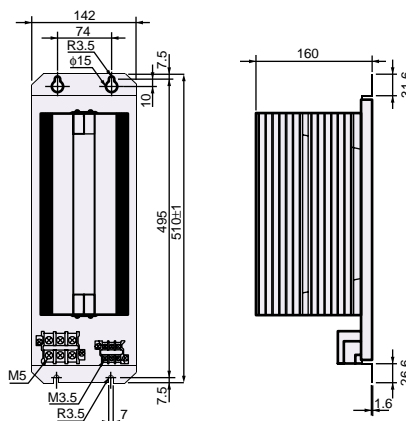

Item	Specifications	
Type	DB22-2	
Resistor	Resistance	5.8Ω
	Allowable power	115W (continuous)
	Working temperature	Opens at 150±10°C
Thermistor	Withstand voltage	2.5kV AC for 1 minute
	Contact capacity	120V AC, 0.1A/30V DC, 0.1A

## Explanation of Model Codes

### ■ Servo amplifier

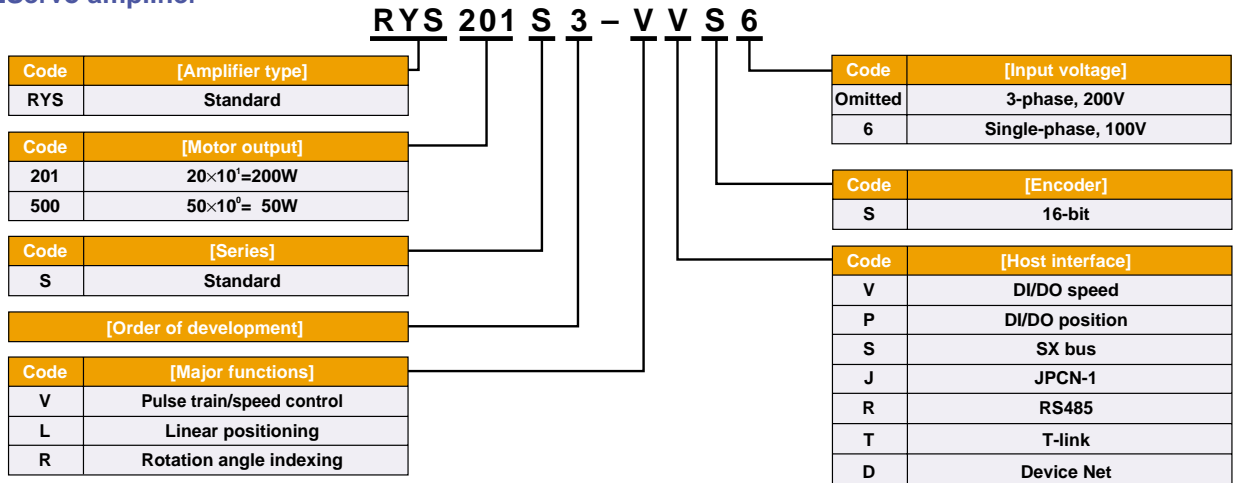

### ■ Servomotor

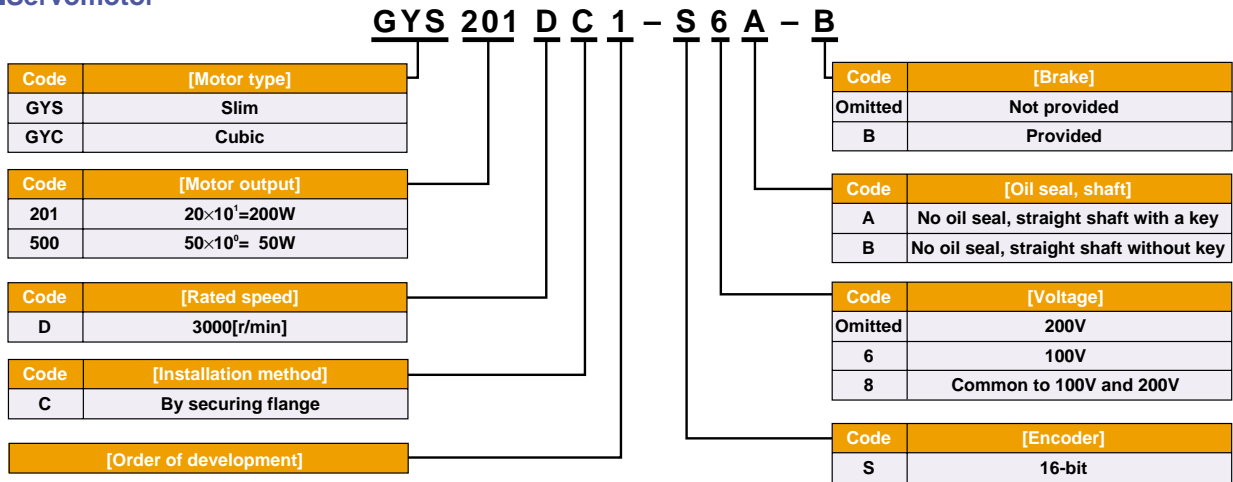

### ■ Gear Head 1

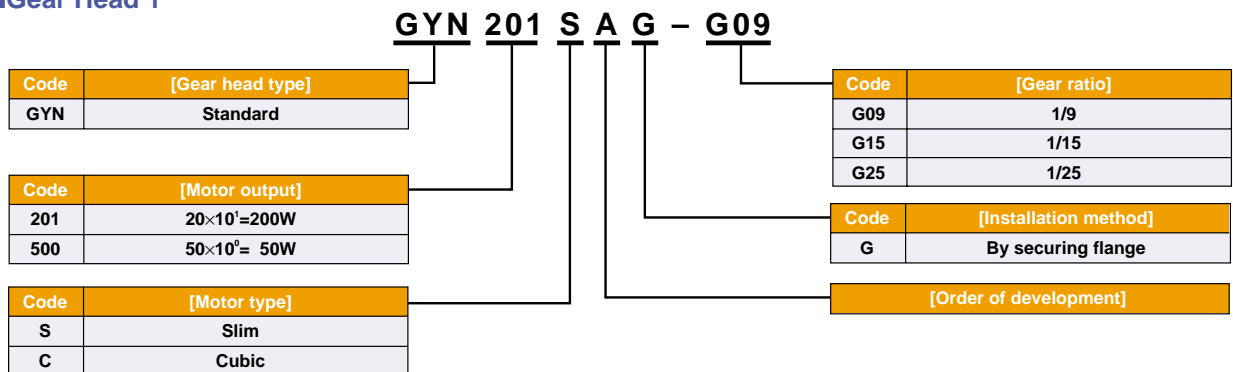

### ■ Gear Head 2

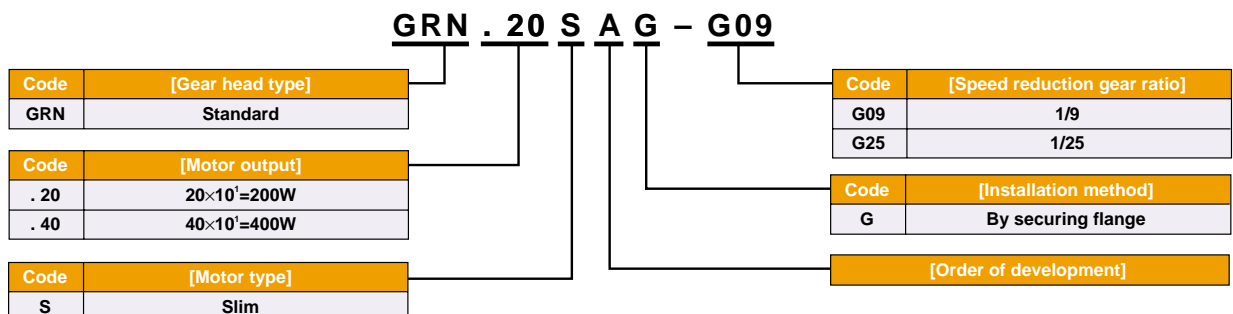

## Type List

### Servomotor

Motor type	Specifications			Part code	Type		
	Voltage	Model	Rated output				
GYC series servomotor (cubic type)	200V	Standard motor	0.1 kW	GYC1000	GYC101DC1-SA		
			0.2 kW	GYC1001	GYC201DC1-SA		
			0.4 kW	GYC1002	GYC401DC1-SA		
			0.75 kW	GYC1003	GYC751DC1-SA		
			1.0 kW	GYC1004	GYC102DC1-SA		
			1.5 kW	GYC1005	GYC152DC1-SA		
		Motor with a brake	2.0 kW	GYC1006	GYC202DC1-SA		
			0.1 kW	GYC1020	GYC101DC1-SA-B		
			0.2 kW	GYC1021	GYC201DC1-SA-B		
			0.4 kW	GYC1022	GYC401DC1-SA-B		
			0.75 kW	GYC1023	GYC751DC1-SA-B		
			1.0 kW	GYC1024	GYC102DC1-SA-B		
			1.5 kW	GYC1025	GYC152DC1-SA-B		
			2.0 kW	GYC1026	GYC202DC1-SA-B		
GYS series servomotor (slim type)	100V/200V	Standard motor	0.05 kW	GYS1001	GYS500DC1-S8B		
	200V	Standard motor	0.1 kW	GYS1002	GYS101DC1-SB		
			0.2 kW	GYS1003	GYS201DC1-SA		
			0.4 kW	GYS1004	GYS401DC1-SA		
			0.75 kW	GYS1005	GYS751DC1-SA		
			1.0 kW	GYS1006	GYS102DC1-SA		
			1.5 kW	GYS1007	GYS152DC1-SA		
			2.0 kW	GYS1008	GYS202DC1-SA		
			3.0 kW	GYS1009	GYS302DC1-SA		
			4.0 kW	GYS1010	GYS402DC1-SA		
			5.0 kW	GYS1011	GYS502DC1-SA		
	100V/200V	Motor with a brake	0.05 kW	GYS1021	GYS500DC1-S8B-B		
	200V	Motor with a brake	0.1 kW	GYS1022	GYS101DC1-SB-B		
			0.2 kW	GYS1023	GYS201DC1-SA-B		
			0.4 kW	GYS1024	GYS401DC1-SA-B		
			0.75 kW	GYS1025	GYS751DC1-SA-B		
			1.0 kW	GYS1026	GYS102DC1-SA-B		
			1.5 kW	GYS1027	GYS152DC1-SA-B		
			2.0 kW	GYS1028	GYS202DC1-SA-B		
			3.0 kW	GYS1029	GYS302DC1-SA-B		
			4.0 kW	GYS1030	GYS402DC1-SA-B		
			5.0 kW	GYS1031	GYS502DC1-SA-B		
			100V	Standard motor	0.1 kW	GYS1042	GYS101DC1-S6B
					0.2 kW	GYS1043	GYS201DC1-S6B
				Motor with a brake	0.1 kW	GYS1052	GYS101DC1-S6B-B
					0.2 kW	GYS1053	GYS201DC1-S6B-B

### Gear Head

Applied motor	Gear ratio	Applied motor capacity	Part code	Type
GYC series servomotor (cubic type)	1/9	0.1kW	GYN100C	GYN101CAG-G09
		0.2kW	GYN101C	GYN201CAG-G09
		0.4kW	GYN102C	GYN401CAG-G09
		0.75kW	GYN103C	GYN751CAG-G09
		1.0kW	GYN104C	GYN102CAG-G09
		1.5kW	GYN105C	GYN152CAG-G09
	1/25	2.0kW	GYN106C	GYN202CAG-G09
		0.1kW	GYN120C	GYN101CAG-G25
		0.2kW	GYN121C	GYN201CAG-G25
		0.4kW	GYN122C	GYN401CAG-G25
		0.75kW	GYN123C	GYN751CAG-G25
		1.0kW	GYN124C	GYN102CAG-G15
	1/15	1.5kW	GYN125C	GYN152CAG-G15
		2.0kW	GYN126C	GYN202CAG-G15
		GYS series servomotor (slim type)	1/9	0.05kW
0.1kW	GYN102S			GYN101SAG-G09
0.2kW	GYN103S			GYN201SAG-G09
	GRN003S			GRN.20SAG-G09
0.4kW	GYN104S			GYN401SAG-G09
	GRN004S			GRN.40SAG-G09
0.75kW	GYN105S			GYN751SAG-G09
1.0kW	GYN106S			GYN102SAG-G09
1.5kW	GYN107S		GYN152SAG-G09	
2.0kW	GYN108S		GYN202SAG-G09	
1/25	0.05kW		GYN121S	GYN500SAG-G25
	0.1kW		GYN122S	GYN101SAG-G25
	0.2kW		GYN123S	GYN201SAG-G25
			GRN013S	GRN.20SAG-G25
	0.4kW		GYN124S	GYN401SAG-G25
		GRN014S	GRN.40SAG-G25	
0.75kW	GYN125S	GYN751SAG-G25		
1/15	1.0kW	GYN126S	GYN102SAG-G15	
	1.5kW	GYN127S	GYN152SAG-G15	
	2.0kW	GYN128S	GYN202SAG-G15	

## Servo Amplifier

Type	Input voltage	Host interface	Applied motor capacity	Part code	Type			
Pulse train/speed control	3-phase 200V	DI/DO	0.05kW	RYS1001	RYS500S3-VVS			
			0.1kW	RYS1002	RYS101S3-VVS			
			0.2kW	RYS1003	RYS201S3-VVS			
			0.4kW	RYS1004	RYS401S3-VVS			
			0.75kW	RYS1005	RYS751S3-VVS			
			1.0kW	RYS1006	RYS102S3-VVS			
			1.5kW	RYS1007	RYS152S3-VVS			
			2.0kW	RYS1008	RYS202S3-VVS			
			3.0kW	RYS1009	RYS302S3-VVS			
			4.0kW	RYS1010	RYS402S3-VVS			
	Single-phase 100V	DI/DO	0.05kW	RYS3073	RYS500S3-VVS6			
			0.1kW	RYS3074	RYS101S3-VVS6			
			0.2kW	RYS3075	RYS201S3-VVS6			
	3-phase 200V	SX bus	0.05kW	RYS3013	RYS500S3-VSS			
			0.1kW	RYS3014	RYS101S3-VSS			
			0.2kW	RYS3015	RYS201S3-VSS			
			0.4kW	RYS3016	RYS401S3-VSS			
			0.75kW	RYS3017	RYS751S3-VSS			
			1.0kW	RYS3018	RYS102S3-VSS			
			1.5kW	RYS3019	RYS152S3-VSS			
			2.0kW	RYS3020	RYS202S3-VSS			
			3.0kW	RYS3021	RYS302S3-VSS			
			4.0kW	RYS3022	RYS402S3-VSS			
			5.0kW	RYS3023	RYS502S3-VSS			
			Linear positioning function built in type	3-phase 200V	DI/DO	0.05kW	RYS3025	RYS500S3-LPS
						0.1kW	RYS3026	RYS101S3-LPS
						0.2kW	RYS3027	RYS201S3-LPS
0.4kW	RYS3028	RYS401S3-LPS						
0.75kW	RYS3029	RYS751S3-LPS						
1.0kW	RYS3030	RYS102S3-LPS						
1.5kW	RYS3031	RYS152S3-LPS						
2.0kW	RYS3032	RYS202S3-LPS						
3.0kW	RYS3033	RYS302S3-LPS						
4.0kW	RYS3034	RYS402S3-LPS						
5.0kW	RYS3035	RYS502S3-LPS						
SX bus	0.05kW	RYS3037			RYS500S3-LSS			
	0.1kW	RYS3038			RYS101S3-LSS			
	0.2kW	RYS3039			RYS201S3-LSS			
	0.4kW	RYS3040			RYS401S3-LSS			
	0.75kW	RYS3041			RYS751S3-LSS			
	1.0kW	RYS3042			RYS102S3-LSS			
	1.5kW	RYS3043			RYS152S3-LSS			
	2.0kW	RYS3044			RYS202S3-LSS			
	3.0kW	RYS3045			RYS302S3-LSS			
	4.0kW	RYS3046			RYS402S3-LSS			
5.0kW	RYS3047	RYS502S3-LSS						
T-link	0.05kW	---			RYS500S3-LTS			
	0.1kW	---			RYS101S3-LTS			
	0.2kW	---			RYS201S3-LTS			
	0.4kW	---			RYS401S3-LTS			
	0.75kW	---			RYS751S3-LTS			
RS485	0.05kW	---			RYS500S3-LRS			
	0.1kW	---			RYS101S3-LRS			
	0.2kW	---			RYS201S3-LRS			
	0.4kW	---			RYS401S3-LRS			
	0.75kW	---			RYS751S3-LRS			
	1.0kW	---			RYS102S3-LRS			
	1.5kW	---			RYS152S3-LRS			
	Rotation angle index function built-in type	3-phase 200V			DI/DO	0.05kW	RYS3049	RYS500S3-RPS
						0.1kW	RYS3050	RYS101S3-RPS
			0.2kW	RYS3051		RYS201S3-RPS		
0.4kW			RYS3052	RYS401S3-RPS				
0.75kW			RYS3053	RYS751S3-RPS				
1.0kW			RYS3054	RYS102S3-RPS				
1.5kW			RYS3055	RYS152S3-RPS				
2.0kW			RYS3056	RYS202S3-RPS				
3.0kW			RYS3057	RYS302S3-RPS				
4.0kW			RYS3058	RYS402S3-RPS				
5.0kW			RYS3059	RYS502S3-RPS				
SX bus			0.05kW	RYS3061	RYS500S3-RSS			
			0.1kW	RYS3062	RYS101S3-RSS			
			0.2kW	RYS3063	RYS201S3-RSS			
			0.4kW	RYS3064	RYS401S3-RSS			
			0.75kW	RYS3065	RYS751S3-RSS			
			1.0kW	RYS3066	RYS102S3-RSS			
			1.5kW	RYS3067	RYS152S3-RSS			
			2.0kW	RYS3068	RYS202S3-RSS			
			3.0kW	RYS3069	RYS302S3-RSS			
			4.0kW	RYS3070	RYS402S3-RSS			
5.0kW			RYS3071	RYS502S3-RSS				
T-link			0.05kW	---	RYS500S3-RTS			
			0.1kW	---	RYS101S3-RTS			
			0.2kW	---	RYS201S3-RTS			
			0.4kW	---	RYS401S3-RTS			
			0.75kW	---	RYS751S3-RTS			
	1.0kW	---	RYS102S3-RTS					
1.5kW	---	RYS152S3-RTS						

## 3-phase 200V series

### Option

Part Name		Part Code	Type	
Cable for input/output of control signals (CN1, CN3)	DI/DO standard 36 pins (CN1)	3m (one-end connector)	RYWS802	WSC-D36P03
	DI/DO extended 20 pins (CN3) for L type and R type		RYWS800	WSC-D20P03
	26 pins (CN1) for SX bus, T-link, RS485		RYWS801	WSC-D26P03
Cable for Servomotor encoder (CN2)	0.75kW or less	5m (both-end connector)	RYWS803	WSC-P06P05
		10m (both-end connector)	RYWS804	WSC-P06P10
		20m (both-end connector)	RYWS805	WSC-P06P20
	1.0kW or over	5m (both-end connector)	RYWS806	WSC-P06P05-C
		10m (both-end connector)	RYWS807	WSC-P06P10-C
		20m (both-end connector)	RYWS808	WSC-P06P20-C
	Common to all the models (connector kit required for motor)	5m (one-end connector)	RYWS821	WSC-P06P05-W
10m (one-end connector)		RYWS822	WSC-P06P10-W	
20m (one-end connector)		RYWS823	WSC-P06P20-W	
Servomotor power cable (without brake)	0.75kW or less	5m (one-end connector)	RYWS809	WSC-M04P05
		10m (one-end connector)	RYWS810	WSC-M04P10
		20m (one-end connector)	RYWS811	WSC-M04P20
Servomotor power cable (with brake)	0.75kW or less	5m (one-end connector)	RYWS815	WSC-M06P05
		10m (one-end connector)	RYWS816	WSC-M06P10
		20m (one-end connector)	RYWS817	WSC-M06P20
Connector kit for control I/O wiring (CN1, CN3)	DI/DO standard 36 pins (CN1)	---	RYWS022	WSK-D36P
	DI/DO extended 20 pins (CN3) L type, R type	---	RYWS020	WSK-D20P
	SX bus, T-link, RS485 26 pins (CN1)	---	RYWS021	WSK-D26P
Connector kit for wiring of encoder (CN2)	Common to all the models	---	RYWS023	WSK-P06P-M
	0.75kW or less	---	RYWS024	WSK-P06P-F
	1kW or over	---	RYWS025	WSK-P06P-C
Connector kit for power cables (without brake)	0.75kW or less	---	RYWS026	WSK-M04P
	Slim type 1.0 to 2.0kW	---	RYWS027	WSK-M04P-CA
	Cubic type 1.0kW or over	---	RYWS031	WSK-M04P-CB
Slim type 3.0kW or over	---			
Connector kit for power cables (with brake)	0.75kW or less	---	RYWS028	WSK-M06P
	Slim type 1.0 to 2.0kW	---	RYWS029	WSK-M06P-CA
	Cubic type 1.0kW or over	---	RYWS032	WSK-M06P-CB
	Slim type 3.0kW or over	---		
Connector kit for control power input	1.5kW or less (L1C, L2C)	---	RYWS030	WSK-L02P
Battery (with connector)	Common to all the models	---	RYWS003	WSB-S
External regenerative resistor	For 0.4kW or less	1m extended line	RYWS010	WSR-401
	For 0.7.5kW	1m extended line	RYWS011	WSR-751
	For 1.0kW, 1.5kW	Terminal base	RYWS012	WSR-152
	2.0kW, 3.0kW (inverter option)	Terminal base	RGWG339	DB11-2
	4.0kW, 5.0kW (inverter option)	Terminal base	RGWG342	DB22-2
Personal computer loader (CD)	Common to all the models	---	RYWS002	WSL-PC
Converter-equipped cable for PC loader	Common to all the models (option for MICREX-SX)	2m (both-end connector)	NP4H004	NP4H-CNV
SX bus extension cable	Common to all the models (option for MICREX-SX)	0.3m (both-end connector)	NP1C001	NP1C-P3

## Alarm list

If an alarm is detected, the detected contents are displayed on the touch panel of amplifier.

Priority order	Display	Description
1	SE	System error
2	OC	Overcurrent
3	OS	Overspeed
4	LV	Low voltage
5	HV	High voltage
6	Et	Encoder trouble
7	Ct	Control circuit trouble
8	Fb	Fuse blown
9	dE	Data error (memory error)
10	CE	Combination error
11	rH2	Resistor heat 2
12	EC	Encoder communication error
13	CtE	Cont (control signal) error
14	OL	Overload
15	AH	Amplifier overheat
16	rH	Baking resistor overheat
17	OF	Over flow (excessive deviation)
18	EH	Encoder overheat
19	AL	Absolute data lost
20	RF	Absolute data overflow
21	tE	Terminal error
22	---	(non)

If several alarms are detected simultaneously, the touch panel displays the alarm with higher priority as indicated above.

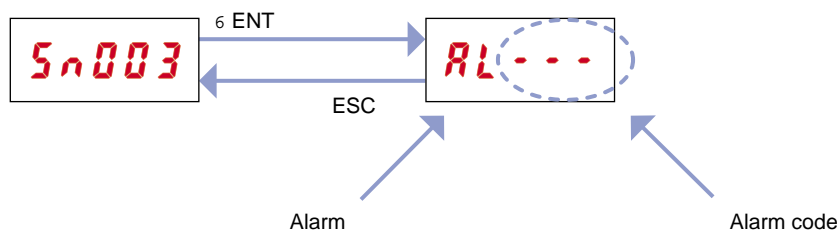



6: 1[sec] min.

### Remarks:

An alarm is displayed automatically if detected.

If, at a displayed status, the alarm detection is reset by a control input signal, the initial screen (system para. 89 setting) appears.

The alarm detection can be reset also in the test running mode [Fn004].

Alarm detection can be reset while the alarm is displayed by holding down the  key and  key simultaneously for at least 1 second.

---

## Fuji Electric FA Components & Systems Co., Ltd.

Gate City Ohsaki, East Tower, 11-2, Osaki 1-chome  
Shinagawa-ku, Tokyo 141-0032, Japan  
Phone: +81-3-5435-7139 Fax: +81-3-5435-7458



Printed on 100% recycled paper